

E96-117

Bailey®  
**infi 90**

# Instruction

## Analog Control Station (IISAC01)

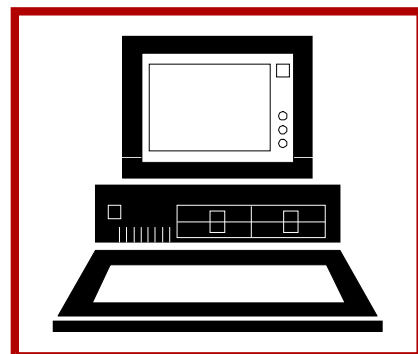
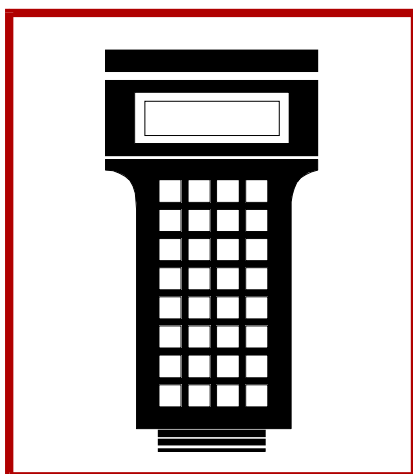
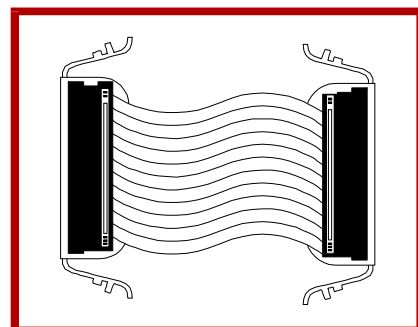
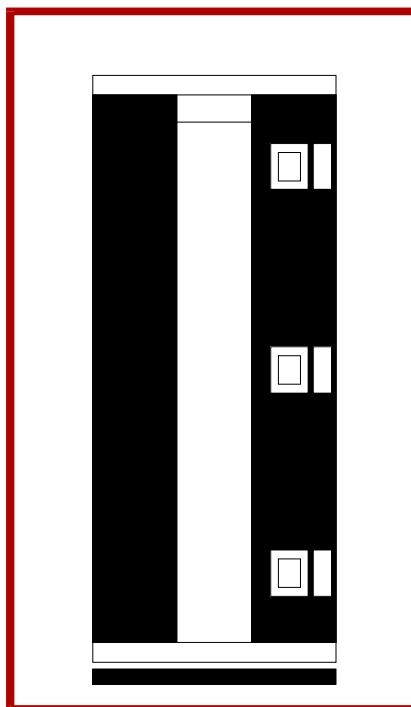
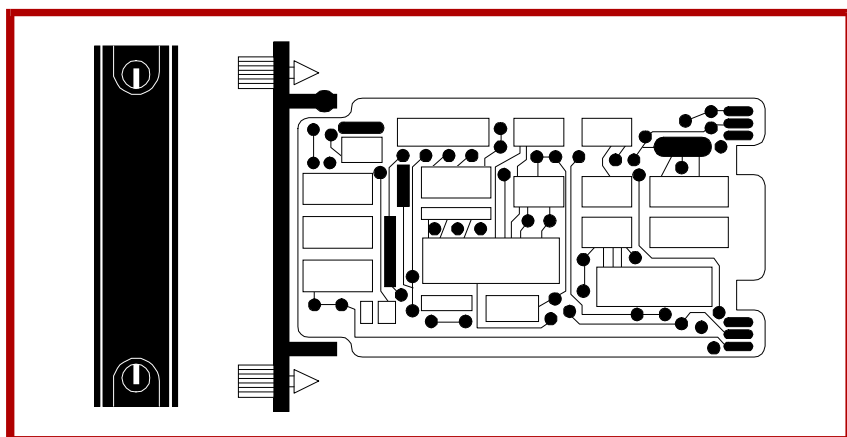
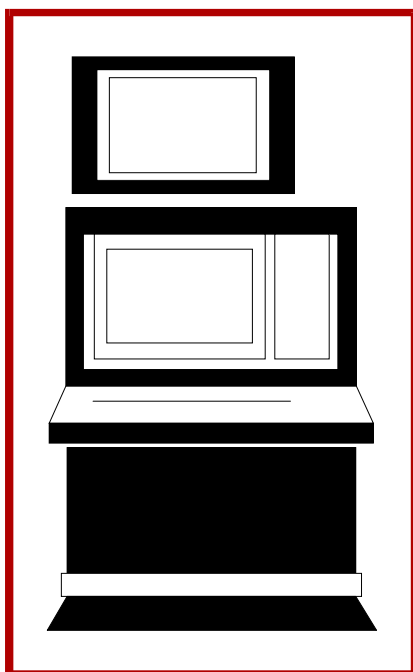

**WARNING** notices as used in this instruction apply to hazards or unsafe practices that could result in personal injury or death.

**CAUTION** notices apply to hazards or unsafe practices that could result in property damage.

**NOTES** highlight procedures and contain information that assists the operator in understanding the information contained in this instruction.

## WARNING

### INSTRUCTION MANUALS

DO NOT INSTALL, MAINTAIN, OR OPERATE THIS EQUIPMENT WITHOUT READING, UNDERSTANDING, AND FOLLOWING THE PROPER **Elsag Bailey** INSTRUCTIONS AND MANUALS; OTHERWISE, INJURY OR DAMAGE MAY RESULT.

### RADIO FREQUENCY INTERFERENCE

MOST ELECTRONIC EQUIPMENT IS INFLUENCED BY RADIO FREQUENCY INTERFERENCE (RFI). CAUTION SHOULD BE EXERCISED WITH REGARD TO THE USE OF PORTABLE COMMUNICATIONS EQUIPMENT IN THE AREA AROUND SUCH EQUIPMENT. PRUDENT PRACTICE DICTATES THAT SIGNS SHOULD BE POSTED IN THE VICINITY OF THE EQUIPMENT CAUTIONING AGAINST THE USE OF PORTABLE COMMUNICATIONS EQUIPMENT.

### POSSIBLE PROCESS UPSETS

MAINTENANCE MUST BE PERFORMED ONLY BY QUALIFIED PERSONNEL AND ONLY AFTER SECURING EQUIPMENT CONTROLLED BY THIS PRODUCT. ADJUSTING OR REMOVING THIS PRODUCT WHILE IT IS IN THE SYSTEM MAY UPSET THE PROCESS BEING CONTROLLED. SOME PROCESS UPSETS MAY CAUSE INJURY OR DAMAGE.

## AVERTISSEMENT

### MANUELS D'OPÉRATION

NE PAS METTRE EN PLACE, RÉPARER OU FAIRE FONCTIONNER L'ÉQUIPEMENT SANS AVOIR LU, COMPRIS ET SUIVI LES INSTRUCTIONS RÉGLEMENTAIRES DE **Elsag Bailey**. TOUTE NÉGLIGENCE À CET ÉGARD POURRAIT ÊTRE UNE CAUSE D'ACCIDENT OU DE DÉFAILLANCE DU MATÉRIEL.

### PERTURBATIONS PAR FRÉQUENCE RADIO

LA PLUPART DES ÉQUIPEMENTS ÉLECTRONIQUES SONT SENSIBLES AUX PERTURBATIONS PAR FRÉQUENCE RADIO. DES PRÉCAUTIONS DEVRONT ÊTRE PRISES LORS DE L'UTILISATION DU MATÉRIEL DE COMMUNICATION PORTATIF. LA PRUDENCE EXIGE QUE LES PRÉCAUTIONS À PRENDRE DANS CE CAS SOIENT SIGNALÉES AUX ENDROITS VOULUS DANS VOTRE USINE.

### PERTURBATIONS DU PROCÉDÉ

L'ENTRETIEN DOIT ÊTRE ASSURÉ PAR UNE PERSONNE QUALIFIÉE EN CONSIDÉRANT L'ASPECT SÉCURITAIRE DES ÉQUIPEMENTS CONTRÔLÉS PAR CE PRODUIT. L'AJUSTEMENT ET/OU L'EXTRACTION DE CE PRODUIT PEUT OCCASIONNER DES À-COUPS AU PROCÉDÉ CONTRÔLE LORSQU'IL EST INSÉRÉ DANS UNE SYSTÈME ACTIF. CES À-COUPS PEUVENT ÉGALEMENT OCCASIONNER DES BLESSURES OU DES DOMMAGES MATÉRIELS.

## NOTICE

The information contained in this document is subject to change without notice.

Elsag Bailey, its affiliates, employees, and agents, and the authors and contributors to this publication specifically disclaim all liabilities and warranties, express and implied (including warranties of merchantability and fitness for a particular purpose), for the accuracy, currency, completeness, and/or reliability of the information contained herein and/or for the fitness for any particular use and/or for the performance of any material and/or equipment selected in whole or part with the user of/or in reliance upon information contained herein. Selection of materials and/or equipment is at the sole risk of the user of this publication.

This document contains proprietary information of Elsag Bailey, Elsag Bailey Process Automation, and is issued in strict confidence. Its use, or reproduction for use, for the reverse engineering, development or manufacture of hardware or software described herein is prohibited. No part of this document may be photocopied or reproduced without the prior written consent of Elsag Bailey.

---

## Preface

---

The IISAC01 Analog Control Station provides an operator interface for INFI 90® system applications. It is a panel mounted device that interfaces directly with a manual/auto transfer station block configured in a multi-function processor module. The analog control station (SAC) displays process variables, allows set point adjustment and provides analog output manual control. It also provides analog output backup in the event of other system faults.

This instruction explains the station features, specifications, and operation. It includes installation procedures and explains how to troubleshoot station failures.

The system engineer or technician using the SAC station should read and understand this instruction before installing and operating the station. In addition, a complete understanding of the INFI 90 system is beneficial.

This update covers error code 16 and contains information on hardware and software improvements.

---

® INFI 90 is a registered trademark of Elsag Bailey Process Automation.

## List of Effective Pages

---

Total number of pages in this instruction is 94, consisting of the following:

| <b>Page No.</b>         | <b>Change Date</b> |
|-------------------------|--------------------|
| Preface                 | 31 August 1994     |
| List of Effective Pages | 31 August 1994     |
| iii through viii        | 31 August 1994     |
| 1-1 through 1-9         | Original           |
| 2-1 through 2-19        | Original           |
| 3-1 through 3-6         | Original           |
| 3-7                     | 31 August 1994     |
| 3-8                     | Original           |
| 3-9 through 3-10        | 31 August 1994     |
| 3-11 through 3-23       | Original           |
| 4-1 through 4-3         | 31 August 1994     |
| 4-4 through 4-9         | Original           |
| 5-1 through 5-2         | Original           |
| 5-3                     | 31 August 1994     |
| 5-4 through 5-13        | Original           |
| 6-1 through 6-4         | Original           |
| 7-1 through 7-2         | Original           |
| 8-1                     | Original           |
| A-1 through A-2         | Original           |
| B-1                     | Original           |
| C-1                     | Original           |
| Index-1 through Index-2 | 31 August 1994     |

When an update is received, insert the latest changed pages and dispose of the superseded pages.

**NOTE:** On an update page, the changed text or table is indicated by a vertical bar in the outer margin of the page adjacent to the changed area. A changed figure is indicated by a vertical bar in the outer margin next to the figure caption. The date the update was prepared will appear beside the page number.

---

## Safety Summary

---

**GENERAL  
WARNINGS**

**Equipment Environment**

All components, whether in transportation, operation or storage, must be in a noncorrosive environment.

**Electrical Shock Hazard During Maintenance**

Disconnect power or take precautions to insure that contact with energized parts is avoided when servicing.

**Special Handling**

This module uses electrostatic sensitive devices.

**SPECIFIC  
WARNING**

Wear eye protection whenever working with cleaning solvents. When removing solvents from printed circuit boards using compressed air, injury to the eyes could result from splashing solvent as it is blown off the printed circuit board. (p. 6-1)

**SPECIFIC  
CAUTION**

Remove a station from its housing before installing or removing the station cable to the station housing. Failure to observe these precautions could result in equipment damage. (p. 3-22)

---

---

## Sommaire de Sécurité

---

**AVERTISSEMENTS  
D'ORDRE  
GÉNÉRAL****Environnement de l'équipement**

Ne pas soumettre les composants à une atmosphère corrosive lors du transport, de l'entreposage ou l'utilisation.

**Possibilité de chocs électriques durant l'entretien**

Débrancher l'alimentation ou prendre les précautions pour éviter tout contact avec des composants sous tension durant l'entretien.

**Precautions de Manutention**

Ce module contient des composants sensibles aux décharges électrostatiques.

**AVERTISSEMENT  
D'ORDRE  
SPÉCIFIQUE**

Portez toujours des lunettes de protection lorsque vous utilisez des solvants de nettoyage. L'air comprimé servant à enlever le solvant des cartes de circuits imprimés provoque des éclaboussures qui risquent d'atteindre les yeux. (p. 6-1)

**ATTENTION  
D'ORDRE  
SPÉCIFIQUE**

Retirer le poste de son boîtier avant d'installer ou de retirer le câble du poste du boîtier. Un manquement à cette précaution pourrait causer des dommages à l'équipement. (p. 3-22)

---

---

# Table of Contents

|  | <i>Page</i> |
|--|-------------|
| <b>SECTION 1 - INTRODUCTION</b> .....  | <b>1-1</b>  |
| INTRODUCTION .....   | 1-1         |
| INTENDED USER .....  | 1-1         |
| HARDWARE DESCRIPTION .....   | 1-1         |
| HARDWARE APPLICATION .....   | 1-2         |
| FEATURES .....   | 1-2         |
| INSTRUCTION CONTENT .....  | 1-3         |
| HOW TO USE THIS INSTRUCTION .....  | 1-4         |
| GLOSSARY OF TERMS AND ABBREVIATIONS .....  | 1-4         |
| REFERENCE DOCUMENTS .....  | 1-6         |
| NOMENCLATURE .....   | 1-7         |
| SPECIFICATIONS .....   | 1-8         |
| <b>SECTION 2 - DESCRIPTION AND OPERATION</b> .....                               | <b>2-1</b>  |
| INTRODUCTION .....   | 2-1         |
| SYSTEM OPERATION .....   | 2-1         |
| Analog Control Station Functions .....   | 2-4         |
| MODES OF OPERATION .....   | 2-5         |
| Initialization .....   | 2-6         |
| Stand-Alone Operation .....  | 2-6         |
| Bypass Operation .....   | 2-6         |
| Manual Override Operation .....  | 2-7         |
| Normal Operation .....   | 2-8         |
| Computer and Local Mode .....  | 2-8         |
| Local Level .....  | 2-9         |
| Computer Level .....   | 2-9         |
| Basic Station .....  | 2-9         |
| Cascade Station .....  | 2-10        |
| Ratio Station .....  | 2-12        |
| SAC STATION I/O CIRCUITRY .....  | 2-13        |
| Bypass Circuitry .....   | 2-14        |
| Electric Drive Circuitry .....   | 2-16        |
| Analog Output Circuitry .....  | 2-18        |
| Analog Input Circuitry .....   | 2-18        |
| <b>SECTION 3 - INSTALLATION</b> .....  | <b>3-1</b>  |
| INTRODUCTION .....   | 3-1         |
| SPECIAL HANDLING .....   | 3-1         |
| UNPACKING AND INSPECTION .....   | 3-2         |
| SELECTING OPTIONS .....  | 3-2         |
| Diagnostics (SW1, Position 1) .....  | 3-3         |
| Communication Rate (SW1, Position 2) .....                                       | 3-3         |
| Station Address (SW1, Positions 3 through 8) .....                               | 3-4         |
| Auto Bypass (SW2, Position 1) .....  | 3-4         |
| Demand Output (SW2, Position 2) .....  | 3-5         |
| Electric Drive Option (SW2, Position 3 and JP2) .....                            | 3-5         |
| DISPLAY OPTIONS .....  | 3-6         |
| Stand-Alone Mode Display Options (SW3) .....                                     | 3-7         |
| Square Root Enable (SW4, Position 1) .....                                       | 3-7         |
| Normal Mode Display Options (SW4, Positions 2, 3 and 4) .....                    | 3-8         |
| Bypass/Manual Override Mode Display Options (SW4, Positions 5, 6, 7 and 8) ..... | 3-8         |
| Manual Override (JP1) .....  | 3-9         |

## Table of Contents (continued)

|   | <i>Page</i> |
|---|-------------|
| <hr/>   |             |
| <b>SECTION 3 - INSTALLATION</b> (continued)                                     |             |
| ELECTRIC DRIVE MODE DISPLAY OPTIONS (SW3 AND SW4) .....                         | 3-10        |
| MICROCOMPUTER MODE OF OPERATION (JP3) .....                                     | 3-11        |
| MOUNTING THE STATION HOUSING .....  | 3-11        |
| Cable Lengths .....   | 3-11        |
| Termination Unit Cable and Wiring Installation (Single or Double Station) ..... | 3-15        |
| Termination Unit Cable Installation (Interconnected Stations) .....             | 3-15        |
| Cable Connections for the NTRL03 Termination Unit .....                         | 3-16        |
| Cable Connections for the NTRL03 Termination Module .....                       | 3-16        |
| Termination Module Cable Installation (without Bypass) .....                    | 3-17        |
| Termination Module Cable Installation (with Bypass) .....                       | 3-19        |
| Connecting Termination Cables to Station Housing .....                          | 3-22        |
| INSERTING AND REMOVING THE ANALOG CONTROL STATION .....                         | 3-22        |
| Inserting the Analog Control Station .....                                      | 3-22        |
| Removing the Analog Control Station .....                                       | 3-23        |
| FUNCTION CODE CONFIGURATION .....   | 3-23        |
| <hr/>   |             |
| <b>SECTION 4 - OPERATING PROCEDURES</b> .....                                   | <b>4-1</b>  |
| INTRODUCTION .....  | 4-1         |
| FACEPLATE OPERATION .....   | 4-1         |
| Alphanumeric Display .....  | 4-1         |
| Annunciators .....  | 4-4         |
| Bar Graph Displays .....  | 4-4         |
| Membrane Pushbuttons .....  | 4-4         |
| Manual Override Switch .....  | 4-4         |
| STATION START-UP AND OPERATION .....  | 4-6         |
| Stand-Alone .....   | 4-7         |
| Normal Operation .....  | 4-8         |
| Changing Control Strategies in Normal Operation .....                           | 4-8         |
| Bypass/Manual Override Operation.....   | 4-9         |
| Acknowledging Alarms.....   | 4-9         |
| <hr/>   |             |
| <b>SECTION 5 - TROUBLESHOOTING</b> .....  | <b>5-1</b>  |
| INTRODUCTION .....  | 5-1         |
| HOW TO USE THIS SECTION .....   | 5-1         |
| ERROR CODES .....   | 5-1         |
| GENERAL FAILURES .....  | 5-1         |
| <hr/>   |             |
| <b>SECTION 6 - MAINTENANCE</b> .....  | <b>6-1</b>  |
| INTRODUCTION .....  | 6-1         |
| PREVENTIVE MAINTENANCE SCHEDULE .....   | 6-1         |
| EQUIPMENT AND TOOLS REQUIRED .....  | 6-2         |
| PREVENTIVE MAINTENANCE PROCEDURES .....   | 6-2         |
| Printed Circuit Board Cleaning .....  | 6-3         |
| General Cleaning and Washing .....  | 6-3         |
| Edge Connector Cleaning .....   | 6-3         |
| Female Edge Connector Cleaning .....  | 6-4         |
| Checking Connections .....  | 6-4         |
| <hr/>   |             |
| <b>SECTION 7 - REPAIR/REPLACEMENT PROCEDURES</b> .....                          | <b>7-1</b>  |
| INTRODUCTION .....  | 7-1         |
| STATION FUSE (F1) REPLACEMENT .....   | 7-2         |



## Table of Contents (continued)

|  | <i>Page</i> |
|--|-------------|
| <b>SECTION 8 - SUPPORT SERVICES</b> .....                              | <b>8-1</b>  |
| INTRODUCTION .....   | 8-1         |
| REPLACEMENT PARTS AND ORDERING INFORMATION .....                       | 8-1         |
| TRAINING .....   | 8-1         |
| TECHNICAL DOCUMENTATION .....  | 8-1         |
| <hr/>  |             |
| <b>APPENDIX A - NTCS04 CONTROLLER/STATION TERMINATION UNIT</b> .....   | <b>A-1</b>  |
| INTRODUCTION .....   | A-1         |
| <hr/>  |             |
| <b>APPENDIX B - NICS01 CONTROLLER/STATION TERMINATION MODULE</b> ..... | <b>B-1</b>  |
| INTRODUCTION .....   | B-1         |
| <hr/>  |             |
| <b>APPENDIX C - NIDS01 STATION TERMINATION MODULE</b> .....            | <b>C-1</b>  |
| INTRODUCTION .....   | C-1         |

## List of Tables

| <i>No.</i> | <i>Title</i>   | <i>Page</i> |
|------------|--|-------------|
| 1-1.       | Glossary of Terms and Abbreviations .....                        | 1-5         |
| 1-2.       | Reference Documents .....  | 1-6         |
| 1-3.       | Nomenclature .....   | 1-7         |
| 1-4.       | IISAC01 Analog Control Station Specifications .....              | 1-8         |
| 2-1.       | Bypass Circuit Functions and Specifications .....                | 2-15        |
| 3-1.       | Dipswitch SW1 Positions 1 and 2 .....                            | 3-3         |
| 3-2.       | Dipswitch SW1 Address Positions 3 through 8 .....                | 3-4         |
| 3-3.       | Dipswitch SW2 Positions 1 through 3 .....                        | 3-5         |
| 3-4.       | SAC Station Jumper Settings .....                                | 3-6         |
| 3-5.       | Dipswitch SW3 Positions 1 through 3 .....                        | 3-7         |
| 3-6.       | Dipswitch SW4 Position 1 .....                                   | 3-8         |
| 3-7.       | Dipswitch SW4 Positions 2 through 8 .....                        | 3-9         |
| 3-8.       | Dipswitch SW3 Electric Drive Mode Display Options .....          | 3-10        |
| 3-9.       | Dipswitch SW4 Electric Drive Mode Display Options .....          | 3-10        |
| 3-10.      | Termination Device and SAC Station Designator Relationship ..... | 3-12        |
| 3-11.      | Cable Applications, Connections and Length Requirements .....    | 3-13        |
| 3-12.      | INFI 90 Power System Maximum Cable Length .....                  | 3-14        |
| 3-13.      | Network 90 Power System Maximum Cable Length .....               | 3-15        |
| 4-1.       | Special Characters on the Alphanumeric Display .....             | 4-2         |
| 4-2.       | Analog Control Station Error Codes and Alarms .....              | 4-2         |
| 4-3.       | Annunciators .....   | 4-4         |
| 4-4.       | Membrane Pushbutton Operation .....                              | 4-5         |
| 5-1.       | Corrective Action for SAC Error Codes .....                      | 5-2         |
| 5-2.       | Troubleshooting General Failures.....                            | 5-12        |
| 6-1.       | Preventive Maintenance Schedule .....                            | 6-2         |
| 7-1.       | Recommended Spare Parts List .....                               | 7-1         |
| A-1.       | NTCS04 Termination Unit Dipshunt Configuration .....             | A-1         |

# List of Figures

| <i>No.</i> | <i>Title</i>   | <i>Page</i> |
|------------|--|-------------|
| 1-1.       | Example Analog Control Station within the INFI 90 Hierarchy .....                              | 1-3         |
| 2-1.       | SAC Station Application Example .....  | 2-2         |
| 2-2.       | Flow Diagram of SAC Station Operation from Power Up to Normal Operation .....                  | 2-5         |
| 2-3.       | SAC Station Normal Operating Modes .....   | 2-8         |
| 2-4.       | Basic Station Configuration .....  | 2-10        |
| 2-5.       | Module Configuration with Cascade Set Point from External Source .....                         | 2-11        |
| 2-6.       | Ratio Station Configuration .....  | 2-12        |
| 2-7.       | Block Diagram of SAC Station Circuitry .....   | 2-13        |
| 2-8.       | Station Bypass Circuitry .....   | 2-15        |
| 2-9.       | Electric Drive Circuit .....   | 2-17        |
| 2-10.      | Analog Output Circuitry .....  | 2-18        |
| 3-1.       | Dipswitch and Jumper Locations on the SAC Station Circuit Board .....                          | 3-2         |
| 3-2.       | Station Housing Panel Cutout and Mounting Dimensions .....                                     | 3-12        |
| 3-3.       | Cable Connections for Two Analog Control Stations on One<br>TCS Termination Unit .....         | 3-16        |
| 3-4.       | Cable Connections for TCS Termination Unit with Multiple Interconnected<br>SAC Stations .....  | 3-17        |
| 3-5.       | Cable Connections for the NTRL03 Termination Unit .....  | 3-18        |
| 3-6.       | Cable Connections for the NIRL03 Termination Module .....                                      | 3-19        |
| 3-7.       | Cable Connections for the ICS Termination Module with One Station,<br>No Bypass .....          | 3-20        |
| 3-8.       | Cable Connections for the ICS and IDS Modules with Interconnected Stations<br>and Bypass ..... | 3-21        |
| 4-1.       | SAC Faceplate .....  | 4-1         |
| 5-1.       | Error Code E01 Troubleshooting Flowchart .....   | 5-5         |
| 5-2.       | Error Codes E03, E04, E05 and E06 Troubleshooting Flowchart .....                              | 5-6         |
| 5-3.       | Error Codes E07 and E08 Troubleshooting Flowchart .....  | 5-7         |
| 5-4.       | Error Code E17 Troubleshooting Flowchart .....   | 5-8         |
| 5-5.       | Error Code E18 Troubleshooting Flowchart .....   | 5-9         |
| 5-6.       | Error Code E19 Troubleshooting Flowchart .....   | 5-10        |
| 5-7.       | Error Code E20 Troubleshooting Flowchart .....   | 5-11        |
| 5-8.       | Troubleshooting Flowchart for General Operational Failures .....                               | 5-13        |
| A-1.       | NTCS04 Terminal Assignments .....  | A-2         |
| B-1.       | NICS01 Terminal Assignments .....  | B-1         |
| C-1.       | NIDS01 Terminal Assignments .....  | C-1         |

---

# SECTION 1 - INTRODUCTION

---

## *INTRODUCTION*

The IISAC01 Analog Control Station provides process loop control and monitoring capabilities for a single loop. The analog control station (SAC), while functionally compatible with the NDCS03 Digital Control Station, includes additional features not found on earlier digital control stations, including:

- Additional analog input display with square root option.
- High resolution bar graph displays.
- Five or 40-kilohertz serial link.

---

## *INTENDED USER*

System engineers and technicians must read this instruction before installing and operating the SAC station. Refer to the Table of Contents to find specific information.

---

## *HARDWARE DESCRIPTION*

The SAC station is a single printed circuit board assembly. The board assembly is housed in a panel mounted plastic case. The faceplate indicators and membrane switches provide the operator interface.

The faceplate has three gas plasma bar graph displays. They provide a high resolution display of:

- Set point.
- Process variable.
- Control output (demand output) data.

An eight-character alphanumeric display shows:

- Process variable value.
- Process variable alarms.
- Set point.
- Control output (demand output).
- Operational mode.
- Error codes.

The front panel pushbuttons:

- Select the alphanumeric display mode.
- Select the station operational mode.
- Raise/lower set point and control output (demand output).
- Select manual override.
- Acknowledge the alarms.

---

## HARDWARE APPLICATION

The SAC station enables monitoring a process or controlling a process manually. One NTCS04 Control I/O Termination Unit or an NICS01 Control I/O Termination Module with an NIDS01 Station Termination Module can interconnect up to eight stations (two chains with four stations per chain). Multiple termination devices may be interconnected together in order to interface the desired number of stations. In an interconnecting arrangement, the first station can have bypass capability. Bypass allows direct control of the final control element (four to 20-milliamp output or electric drive). IMMFP01 and IMMFP02 Multi-Function Processors with firmware revision level higher than C\_0, or IMMFP03<sup>1</sup> Multi-Function Processors with any revision level can interface a maximum of 64 stations. Figure 1-1 shows an example of SAC stations within the INFI 90 hierarchy.

---

## FEATURES

Low cost and compact size make the analog control station a convenient way to add stations that have operator interface capabilities. The maximum allowable number of stations is 64 when using an IMMFP01 or IMMFP02 module (firmware revision level C or higher and operating at 40 kilobaud) unless used in conjunction with an NDIS01 digital indicator station. All other applications allow a maximum of eight stations.

The SAC station operates in three modes depending on module configuration: Basic, cascade, or ratio. The control strategies for each station type reside in the module.

Selectable station options allow a standard current output (four to 20 milliamps) or contact relay outputs for electric drives when the station enters bypass operation or manual override. Additional option selections include:

- Faceplate display format for each mode of operation.

---

1. . Other modules include the IMMFC03, IMMFC04 and IMMFC05 Multi-Function Controller Modules, the IMCOM03 and IMCOM04 Controller Modules and the IMQRC01 Quick Response Controller Module. Their functionality within the control system is similar to the MFP module except that each module varies in control capabilities (operating specifications).

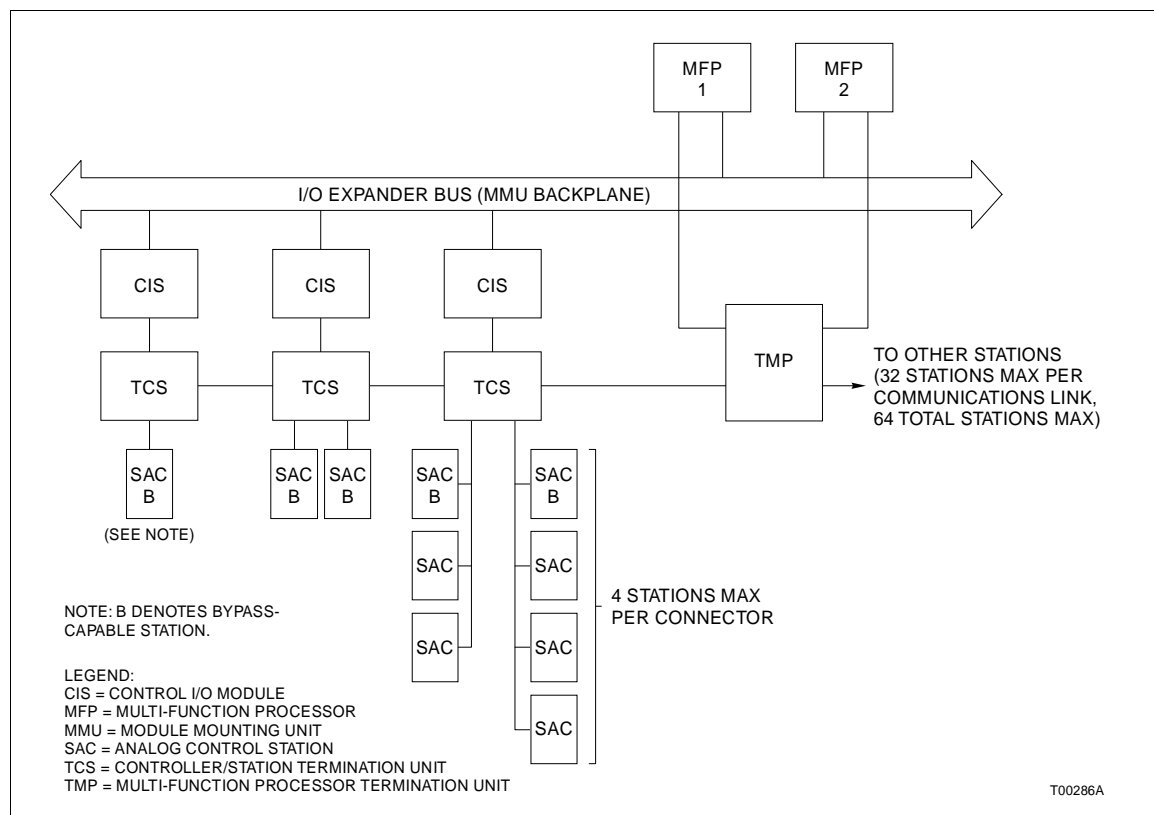

Figure 1-1. Example Analog Control Station within the INFI 90 Hierarchy

- Reverse acting analog output.
- Square root function on the second analog input.
- Electric drive option enable/disable.
- Five or 40-kilobaud serial link station to module communication rate.
- Auto bypass enable/disable.
- Replaceable engineering unit scales for process variable and set point.

## INSTRUCTION CONTENT

This instruction provides introductory, installation, operation, troubleshooting and maintenance information. Read and understand this document before placing the analog control

station into service. This instruction contains the following sections:

|                                      |   |
|--------------------------------------|---|
| <b>Introduction</b>                  | Contains an overview of the system, description of hardware, glossary of terms and abbreviations, reference documentation and specifications.                 |
| <b>Description and Operation</b>     | Uses block diagrams, schematics and text to explain module operation.   |
| <b>Installation</b>                  | Covers the preliminary steps to prepare the module for operation. It covers handling, inspection, SAC station options (dipswitch settings) and configuration. |
| <b>Operating Procedures</b>          | Provides information on station start-up, front panel controls and basic operation of the SAC station.  |
| <b>Troubleshooting</b>               | Lists station status messages, error codes and corrective action for SAC station failures.  |
| <b>Maintenance</b>                   | Contains a table of scheduled maintenance procedures.   |
| <b>Repair/Replacement Procedures</b> | Explains how to repair and replace the SAC station.   |
| <b>Support Services</b>              | Explains the services and training that Bailey Controls Company makes available to their customers.   |
| <b>Appendices</b>                    | Supply quick reference information on the termination devices.  |

---

## **HOW TO USE THIS INSTRUCTION**

Read this instruction in sequence. It is important to become familiar with the entire contents of this instruction before using the SAC station. The organization of this instruction enables finding needed information quickly.

1. Do the steps in **Section 3**.
2. Read **Section 4** thoroughly before powering up the station.
3. Refer to **Section 5** if a problem occurs.
4. Refer to **Section 6** for scheduled maintenance requirements.
5. Use **Section 8** for a list of replacement parts information.

---

## **GLOSSARY OF TERMS AND ABBREVIATIONS**

Table **1-1** lists definitions of the terms and abbreviations used in this instruction.

Table 1-1. Glossary of Terms and Abbreviations

| Term                       | Definition  |
|----------------------------|---|
| A/D Conversion             | Analog-to-digital conversion. Process of generating a digital representation of the magnitude of an analog signal.  |
| Basic Station              | An analog control station configuration that allows the operator to adjust the set point in the automatic mode (closed-loop control) and the control output in the manual mode (open-loop control). One of 3 station types available in the normal operating mode.  |
| Bypass Operation           | An analog control station operating mode that provides control output for a process. Bypass operation gives the operator direct control of the output if a primary module or control I/O slave module failure occurs.   |
| Cascade Station            | An analog control station configuration that allows an externally generated signal, such as the output of an upstream controller, to control the set point. One of 3 station types available in the normal operating mode.  |
| Closed-Loop Control System | A control system in which the controlled variable is measured and compared with a standard (set point) representing the desired performance. From this comparison (feedback), the system compensates to eliminate any deviation between the set point and the controlled variable.                            |
| Control Output             | The control system signal that influences the operation of a final control element.   |
| D/A Conversion             | Digital-to-analog conversion. Process of generating an analog signal of a magnitude that corresponds to a digital value.  |
| Demand Output              | The desired control output of the analog control station when it is in bypass operation.  |
| Manual Override            | An operator initiated mode which has similar functionality as bypass mode. This mode is entered independently of the state of the primary module and CIS module. The SAC station ignores all serial link communications with the module while in this mode. The SAC station controls the process directly.    |
| MFT                        | Machine fault timer. Reset by the processor during normal operation. If not reset regularly, the MFT times out and the module stops.  |
| Open-Loop Control System   | A control system where no function of the controlled variable is used for automatic control of the system. It is not a feedback control system.   |
| PID                        | Proportional plus integral plus derivative control action. Control action in which the output is proportional to a linear combination of the input, the time integral of input and the time rate-of-change of input.  |
| Primary Module             | Active module in a redundant configuration.   |
| Process                    | The collective predetermined functions performed in and by the equipment in which a variable is to be continuously controlled.  |
| Process Variable           | An input that is used by the control strategy of a control device.  |
| Ratio Station              | An analog control station configuration that maintains a ratio between two variables. The ratio of an externally generated wild variable times the controlled variable becomes the set point that provides regulation of a third variable. One of three station types available in the normal operating mode. |
| RS-232-C and RS-485        | Two serial communication interface standards developed by the Electronics Industry Association (EIA) specifying what signals and voltages will be used to transmit data from a computer (DTE) to a modem (DCE).   |
| Set Point                  | Target set for a process variable or standard representing desired value of the process variable.   |

Table 1-1. Glossary of Terms and Abbreviations (continued)

| Term               | Definition   |
|--------------------|--|
| Stand-Alone        | An analog control station operating mode that occurs when the module cannot establish communication with the station during initialization. This mode displays analog inputs and allows the targeting (adjustment) of the demand output to match the actual output when normal operation begins. |
| Termination Module | Provides input/output connection between plant equipment and the INFI 90/Network 90® modules.  |
| Termination Unit   | Provides input/output connection between plant equipment and the INFI 90/Network 90 modules.   |
| Wild Variable      | A variable that is used as a reference for a control loop.   |

---

**REFERENCE DOCUMENTS**

Table 1-2 lists the documents referenced in this instruction.

Table 1-2. Reference Documents

| Number      | Title  |
|-------------|--|
| I-E92-500-3 | CBC01 Batch Command Controller                         |
| I-E92-500-7 | CLC03/04 Loop Command Controller                       |
| I-E96-116   | NDIS01 Digital Indicator Station                       |
| I-E96-200   | Function Code Application Manual                       |
| I-E96-201   | IMMFP01 Multi-Function Processor                       |
| I-E96-202   | IMMFP02 Multi-Function Processor                       |
| I-E96-203   | IMMFP03 Multi-Function Processor                       |
| I-E96-207   | IMCOM03 and IMCOM04 Controller                         |
| I-E96-211   | IMMFC03 Multi-Function Controller                      |
| I-E96-212   | IMMFC04 Multi-Function Controller                      |
| I-E96-213   | IMMFC05 Multi-Function Controller                      |
| I-E96-215   | IMQRC01 Quick Response Controller                      |
| I-E96-306   | IMCIS02 Control I/O Slave Module                       |
| I-E96-317   | IMRIO02 Remote I/O Slave Module                        |
| I-E96-401   | NIMP01/02 Multi-Function Processor Termination Module  |
| I-E96-409   | NICS02 Control Station Termination Module              |
| I-E96-412   | NIDS01 Station Termination Module                      |
| I-E96-413   | NIMF01/02 Multi-Function Controller Termination Module |
| I-E96-415   | NIRL03 Remote Link Termination Module                  |
| I-E96-427   | NTMF01 Multi-Function Controller Termination Unit      |

---

® Network 90 is a registered trademark of Elsas Bailey Process Automation.



Table 1-2. Reference Documents (continued)

| Number    | Title  |
|-----------|--|
| I-E96-428 | NTMP01 Multi-Function Processor Termination Unit                                       |
| I-E96-429 | NTRL02 and NTRL03 Fiber Optic Remote Link and Electrical Remote Link Termination Units |
| I-E96-442 | NTCS04 Controller Station Termination Unit   |
| I-E96-500 | Site Planning and Preparation  |

**NOMENCLATURE**

Table 1-3 is a list of related hardware.

Table 1-3. Nomenclature

| Nomenclature  | Hardware                                    |
|---------------|---|
| CKS001        | CLC controller cable                        |
| CKS002        | CBC controller cable                        |
| IISAC01       | Analog control station                      |
| IMCIS02       | Control I/O slave module                    |
| IMCOM03/04    | Controller modules                          |
| IMMFC03/04/05 | Multi-function controller                   |
| IMMFP01/02/03 | Multi-function processor                    |
| IMQRC01       | Quick response controller                   |
| NDCS03        | Digital control station                     |
| NICS01        | Control I/O termination module              |
| NIDS01        | Station termination module                  |
| NIMP01/02     | Multi-function processor termination module |
| NIRL03        | Remote link termination module              |
| NKCS01/02     | SAC station cable                           |
| NKCS11/12     | SAC station cable non-PVC                   |
| NKDS01        | DCS cable                                   |
| NKDS02        | DCS cable with interconnection              |
| NKDS03        | DCS cable with connector                    |
| NKDS11        | DCS cable non-PVC                           |
| NKDS12        | DCS cable with interconnection non-PVC      |

Table 1-3. Nomenclature (continued)

| Nomenclature | Hardware                               |
|--------------|--|
| NKDS13       | DCS cable with connector non-PVC       |
| NKSE01       | Station serial extension cable         |
| NKSE02       | Station serial extension cable non-PVC |
| NKTD01/02    | Termination station cable              |
| NKTD11 /12   | Termination station cable non-PVC      |
| NKTU01       | Termination unit cable                 |
| NKTU11       | Termination unit cable non-PVC         |
| NTCS04       | Control I/O termination unit           |
| NTRL03       | Remote link termination unit           |

---

**SPECIFICATIONS**

Table 1-4 lists the specifications of the SAC station.

Table 1-4. IISAC01 Analog Control Station Specifications

| Property  | Characteristic/Value  |
|---|---|
| Displays  | 3 gas plasma bar graphs (200 segments for process variable and set point at 0.5% resolution, 100 segments for output at 1.0% resolution)<br>8-character, 14-segment, alphanumeric display   |
| Bypass  | Automatic entry or selected from faceplate  |
| Communication   | 5 or 40 kbaud RS-485 serial link to the controlling module through the termination unit<br>40 kbaud with any IMMFP03 module or IMMFP01 and IMMFP02 module with firmware revision level C_0 or higher<br>All other modules are 5 kbaud |
| Size  | 72 mm x 144 mm x 381 mm (2.82 in. x 5.67 in. x 15.0 in.)  |
| Mounting  | Flush panel mounting  |
| Supply voltage<br>(at the termination device)   | 21.6 VDC minimum, 27.0 VDC maximum  |
| Power consumption<br>(at the termination device)  | 540 mA at 24 VDC  |
| Analog output:<br>Current<br>Maximum load (compliance)<br>Accuracy<br>D/A resolution<br>Maximum load inductance | 3 to 21 mA<br>600 $\Omega$ maximum<br>2.0% of span at 25°C (77°F)<br>8 bits<br>600 mH   |

Table 1-4. IISAC01 Analog Control Station Specifications (continued)

| Property   | Characteristic/Value  |
|--|---|
| Analog input:<br>Voltage range<br>Impedance<br>Accuracy<br>A/D resolution<br>Normal mode rejection<br>Common mode rejection<br>Common mode voltage | +0.75 VDC to +5.25 VDC maximum<br>>10 M $\Omega$<br>1.5% of span at 25°C (77°F)<br>8 bit<br>75 dB minimum at 60 Hz<br>90 dB minimum at 60 Hz<br>$\pm$ 5 VDC maximum |
| Electric drive:<br>R/L Contact<br>M/A Signal<br>M/A Power  | 100 mA maximum (sink or source)<br>100 mA maximum (sink or source)<br>21.6 to 27 VDC  |
| Electromagnetic/radio frequency interference   | Values are not available at this time. Do not use communication equipment any closer than 2 meters from the station panel.  |
| Ambient temperature  | 0° to 70°C (32° to 158°F)   |
| Humidity   | 5% to 90% relative humidity up to 55°C (131°F) (noncondensing)<br>5% to 40% relative humidity at 70° C (158°F) (noncondensing)                                      |
| Atmospheric pressure   | Sea level to 3 km (1.86 mi)   |
| Air quality  | Noncorrosive  |
| Certification  | CSA certified for use as process control equipment in an ordinary (non-hazardous) location.   |

SPECIFICATIONS SUBJECT TO CHANGE WITHOUT NOTICE.

---

## SECTION 2 - DESCRIPTION AND OPERATION

---

### INTRODUCTION

This section contains an explanation of the operation of the IISAC01 Analog Control Station. It gives an overview of station operation within a control system.

---

### SYSTEM OPERATION

A control strategy using analog control stations (SAC) is accomplished by using function blocks configured within a module. The module could be a multi-function processor<sup>1</sup> (MFP). The MFP module receives its inputs from a control I/O slave (CIS) module. The CIS module drives the control output signal under normal operating conditions as directed by the MFP module. The SAC station can drive the output signal during one of the following conditions:

- The MFP module directs the SAC station to enter bypass mode.
- Communication with the MFP module is lost and the auto bypass option is enabled (forces the station into bypass mode).
- The operator forces the station into manual override mode of operation.

Field interfacing is accomplished through a termination device via a cable connection. The CIS module communicates to the MFP module through the I/O expander bus. The SAC station receives and sends information from and to the MFP module through the termination devices. Figure 2-1 shows an example application.

During normal/automatic operation, the CIS module provides digitized analog signals representing the process variable to the MFP module. The operator selects a set point using the set point pushbuttons on the station faceplate. The SAC station sends the set point value to the MFP module for algorithm processing. The MFP module generates a control output value based on its algorithm processing. The control output value is sent to the CIS module where it becomes a control output value to a field device.

When the operator places the SAC station in manual operation, the operator sets the control output value via raise/lower pushbuttons, not the MFP module control algorithm. The

---

1. . Other modules include the IMMFC03, IMMFC04 and IMMFC05 Multi-Function Controller Modules, the IMCOM03 and IMCOM04 Controller Modules and the IMQRC01 Quick Response Controller Module. Their functionality within the control system is similar to the MFP module except that each module varies in control capabilities (operating specifications).

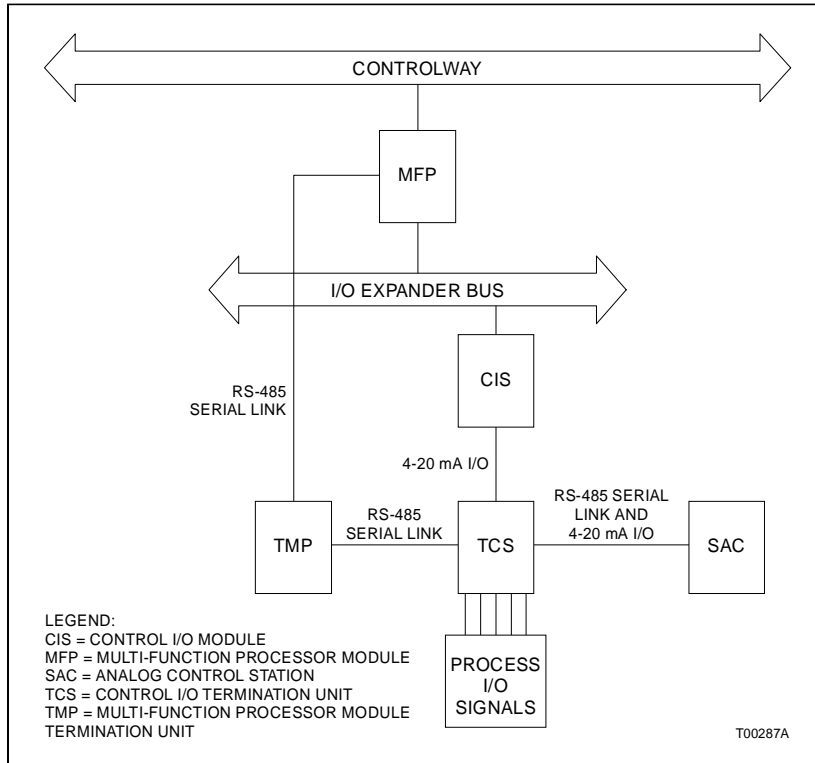

Figure 2-1. SAC Station Application Example

process variable (PV), set point (SP) and control output (CO) are displayed on the SAC station faceplate.

The SAC station control functionality is contained in the MFP module configuration. The control station function code (function code 80) determines the type of station (basic, cascade, or ratio) and other operating parameters. The SAC station provides the operator interface. This interface includes:

- Bar graphs.
- Pushbuttons.
- Annunciators.
- Alphanumeric displays.

The SAC station can be forced to take control of the analog output under three conditions.

1. The MFP module directs the SAC station to bypass mode.
2. The SAC station goes into bypass mode when the auto bypass option is enabled.
3. The operator forces the SAC station into manual override mode and controls the analog output (demand output) manually instead of the CIS module.

The CIS may be removed and replaced without affecting the station supplied demand output. The demand output is manipulated by using the membrane pushbuttons located on the station faceplate. The faceplate bar graphs may be configured to display the demand output value or the two analog inputs as required by the control application.

The operational difference between bypass and manual override is how the MFP module communication operates. In bypass mode, the station deciphers and acts upon all of the MFP module update messages when communication with the primary module exists. In manual override, the station deciphers the MFP module update message but ignores any request to transfer to any other operating mode.

The station can only be forced to exit manual override by an operator action. When the station exits manual override it goes to bypass mode. The station cannot exit bypass mode and go to normal mode until the MFP module update message directs the station to enter normal mode. In normal mode, the MFP module and CIS module have control of the analog output.

For electric drive control applications, the SAC station provides a specific manual operating mode. The SAC station asserts a signal M/A\_SELECT when the electric drive option is enabled and the station is in stand-alone, manual override or bypass mode. The M/A\_SELECT signal forces the electric drive to respond only to contact inputs. Raise/lower contacts are provided to change the position of the electric drive. In electric drive mode, the four to 20-milliamp output signal is disabled. Analog input values can be displayed on the faceplate bar graphs.

A SAC station may be removed and inserted under power. The station configuration in the MFP module continues to operate even when the SAC station is removed.

---

**Analog Control Station Functions**

The functions of the SAC station are to:

1. Provide process variable, set point and analog output displays (bar graph and alphanumeric).
2. Provide set point adjustment.
3. Allow M/A selection of the control loop.
4. Provide analog output backup for the CIS module in the event of a system fault.
5. Provide raise/lower contacts for electric drive manual operation in the event of system fault.
6. Provide alarms for high/low limits or station operation faults.
7. Provide selection options for computer control, ratio station parameters or cascade station parameters.

The SAC station communicates to the MFP module through an RS-485 serial link. Through this serial link, the SAC station receives initialization and update messages from the MFP module. Update messages contain process values to display on the station faceplate bar graph and alphanumeric display. The messages also contain information that directs station operation. In return, the station sends control output (in manual operation), set point (in manual or automatic operation) and pushbutton information to the MFP module.

The MFP module can force the SAC station into and out of bypass mode of operation through an update message. The station still sends the set point to the MFP module when in bypass mode. However, the set point cannot be changed or displayed in bypass mode. The operator controls the demand output through pushbuttons on the SAC station faceplate (open loop control). During bypass operation, the MFP module targets the control output it normally sends to the CIS module to match the demand output from the SAC station. Targeting the control output prevents a significant disturbance in the control output when the MFP module resumes control through the CIS module.

The SAC station, when in manual override mode, responds to MFP module update messages differently than when in bypass mode. When the station is in manual override mode, it ignores any MFP module update request to exit into any other mode of operation. The station only responds to an update message operating mode transfer request after the operator forces the

station out of manual override. The station still sends set point and target demand output values to the MFP module as in bypass mode.

**MODES OF OPERATION**

The MFP module configuration combined with the option settings on the SAC station determine how the station will operate in each operational mode. The block diagram in Figure 2-2 shows the path (operational modes) of station operation from power up to normal operation.

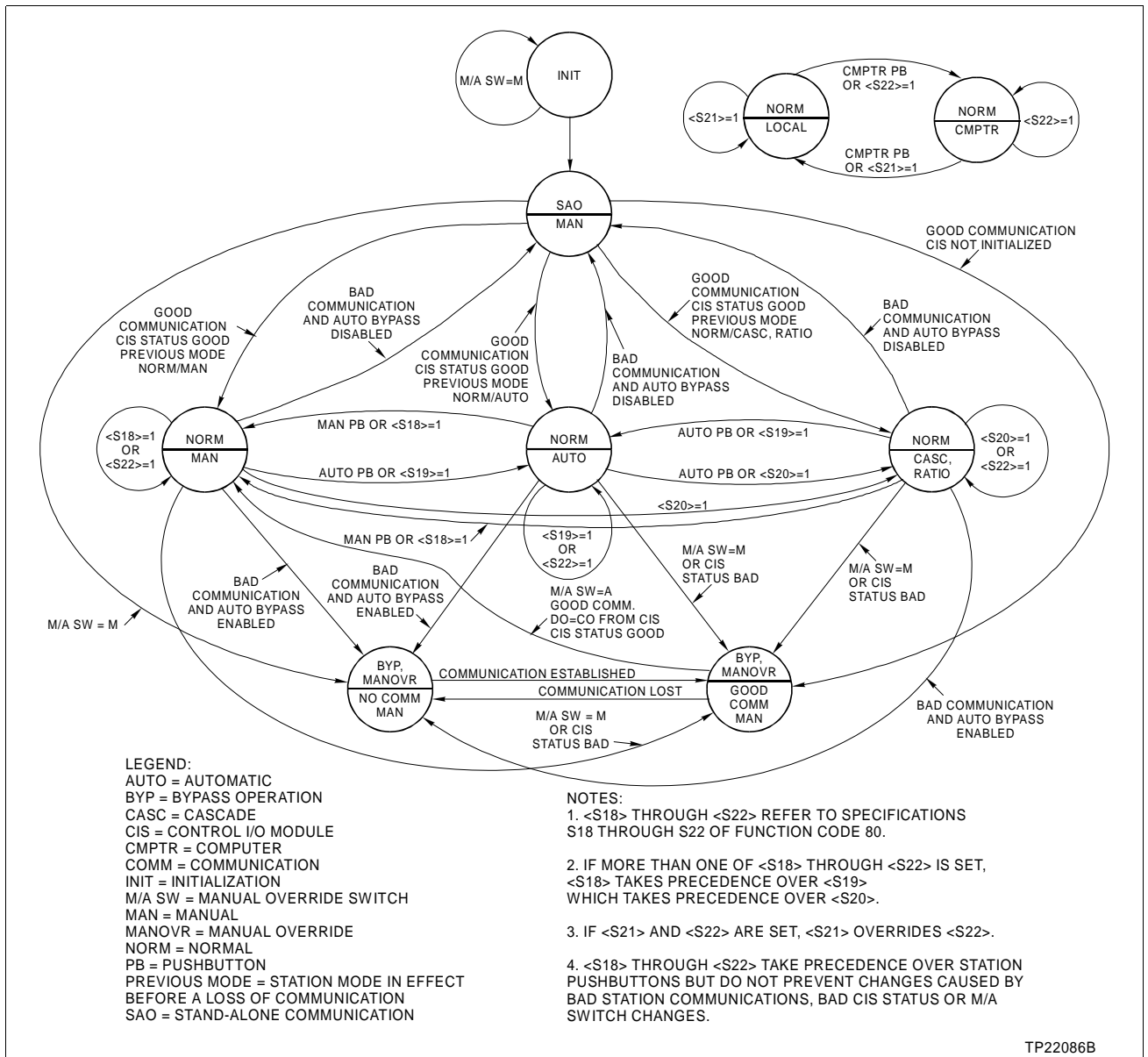

Figure 2-2. Flow Diagram of SAC Station Operation from Power Up to Normal Operation



---

**Initialization**

Upon power up, the station enters the initialization operational mode. Initialization prepares the station hardware for operation. It starts the watchdog timer and runs a test sequence on the faceplate displays. The MFP module reads the station option dipswitch settings and interprets how the station will operate. After initialization is complete, the station enters the stand-alone mode of operation.

---

**Stand-Alone Operation**

The SAC station enters the stand-alone operational mode after initialization. It can also enter stand-alone from the normal operating mode when it loses the communication link with the MFP module and the auto bypass option is disabled. While in stand-alone, the SAC station has no input to process control; it can only monitor the process. The MFP module attempts to communicate with the SAC station by polling for it every 15 seconds. If the SAC station and MFP module cannot establish communication, the SAC station remains in stand-alone unless the operator places it in manual override.

In stand-alone, the CIS module still provides the control output. The SAC station cannot directly control the process but, the operator can monitor the electric drive position or current output through the analog inputs. For manual override, the operator can target the demand output of the SAC station to the control output value of the CIS module using the output raise/lower pushbutton. Targeting the control output on the station gives a smooth transfer of control if the operator desires to place the station in manual override (demand output directly from the station). The station exits stand-alone mode by either operator action (forcing the station to manual override) or MFP module direction (established communications).

---

**Bypass Operation**

In the bypass operational mode, the SAC station drives the control output (analog output or positions the electric drives depending on which option is selected by the station dipswitch settings). The SAC station enters bypass operation if a communication failure occurs while the SAC station is in normal operation (auto bypass option enabled) or the MFP module forces the SAC station into bypass (no communication loss).

If the MFP module shows the associated CIS module analog output (from function code 80, S28) as bad quality, the SAC station goes into bypass (no communication loss). The bad quality detection of the associated CIS module analog output can be the result of either a primary analog output failure or an open in the field wiring. If field wiring is the cause of the station

being forced into bypass, refer to **Section 5** for corrective action.

**NOTE:** The associated analog output is specified by S28 of function code 80 and must reference one of the analog outputs (N+4 or N+5) of function code 79.

Once in the bypass mode, the SAC station cannot return to normal operation until all of the following conditions are met:

1. The MFP module establishes communication with the SAC station.
2. The MFP module targets the CIS module analog output to match the station demand output.
3. The primary analog output failure in the CIS module is corrected.
4. The M/A switch on the SAC station is placed in the **A** position.

When the station enters bypass, it begins driving the analog output using the last value of the CIS module analog output (received in an update message). The demand output can be adjusted from the control output raise/lower pushbuttons. If the electric drive option is selected, the operator directly controls the drive in manual mode using the stations raise/lower contacts (pushbuttons). The output raise/lower contacts on the faceplate energize the drive raise or lower relay circuitry.

---

### ***Manual Override Operation***

The manual override operational mode is functionally similar to the bypass mode of operation. The SAC station in this mode acts as an open loop (manual) controller. All bar graph display mode options and control outputs (analog or electric drive) are the same as in the bypass operational mode. What differentiates the two modes is that in manual override, the station ignores the serial link communications commands from the MFP module to transfer into any other mode of operation. If the serial link communication with the MFP module is still established while in this mode, the SAC station processes all other MFP module update message information.

This mode can be entered independent of the state of the MFP module or CIS module. To enter this mode the operator places the switch under the legend door of the faceplate into the **M** position. To exit this mode place the switch to the **A** position. If communication with the MFP module is not established when the switch is in the **A** position the station enters bypass operational mode. With communications established the station

transfers to either normal mode or reverts back to bypass mode as directed by the MFP module.

---

### **Normal Operation**

Normal operation begins after the MFP module establishes communication with the SAC station. In normal operation, the set point, process variable, control output and analog inputs appear on the appropriate bar graph on the SAC station faceplate. The bar graph format is selected by setting the display option dipswitches on the SAC station circuit board. In the normal operation mode, the SAC station operates as a local, manual/automatic basic or automatic cascade/ratio station. Figure 2-3 shows a diagram of SAC station normal operating modes. When the station loses communication with the MFP module, it defaults to either the stand-alone mode or bypass mode operation (if the auto bypass option is enabled).

---

### **Computer and Local Mode**

A station may operate at one of two levels of process supervision and control. The two levels are local and computer. The level of the station defines whether the supervision and control of the station is to be performed by a human operator via the SAC faceplate controls or the equivalent station faceplate on a console keyboard (local level) or by a supervisory computer program that communicates with the station via a computer interface.

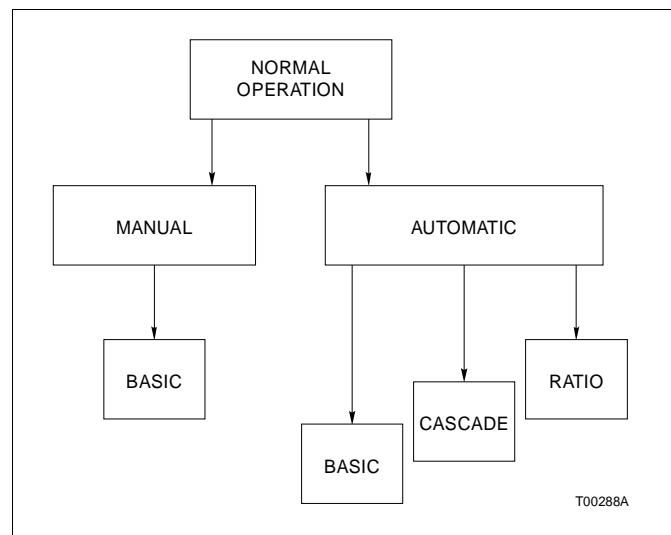

*Figure 2-3. SAC Station Normal Operating Modes*

---

**LOCAL LEVEL**

The local level of supervisory control is the most common. It is used in PID control loops that require occasional monitoring and adjustment of an operator. When the station is at the local level, the operator can control the process from the SAC station or from a console by changing the station mode, station level, control output, set point, and ratio index values.

---

**COMPUTER LEVEL**

The computer level of supervisory control is used when a PID control loop is directly supervised and controlled by an external supervisory computer program, not an operator. When the station is at the computer level, the operator cannot change the station mode, control output, set point, or ratio index values via the SAC station faceplate. However, the operator can place the station to the local level by pressing the CMPTR or MAN pushbutton on the SAC station faceplate.

When at the computer level, the control strategies (basic, ratio and cascade) and the station modes (manual, automatic and cascade/ratio) operate in the same manner as they do at the local level. The only difference is that the station variables are controlled by the external station interface.

The station function code (function code 80) operates a computer watchdog timer that must be started by the supervisory computer program periodically. The watchdog timer is started when the computer program changes the station mode, a station variable while at the computer level, or when it issues a computer OK command at either level. When a watchdog timer time-out occurs, the station reverts back to a predetermined computer backup state.

---

**Basic Station**

The basic station operates in either automatic (closed) or manual (open) loop control. The operator manipulates the process by means of the faceplate pushbuttons. The station interfaces into the customer process by different means while in automatic or manual. In manual (open loop control), the SAC station manipulates the control output by updating the MFP module with control output values that are written to the CIS module that drives the analog output. The set point value can be modified and goes to the MFP module in every station update message but has no effect on the process.

In automatic (closed loop control), the station operator generated set point value is used by the MFP module PID algorithms to manipulate the process. The operator cannot establish a control output value with the output raise/lower pushbuttons

while in automatic mode. Figure 2-4 shows an example of how function code 80 works as a basic station.

**Cascade Station**

Cascade station operation is similar to automatic basic station operation except that the set point of the cascade station is from an external source. Cascade operation inhibits set point adjustment from the station faceplate. Cascade station operates only in the automatic local and automatic/computer

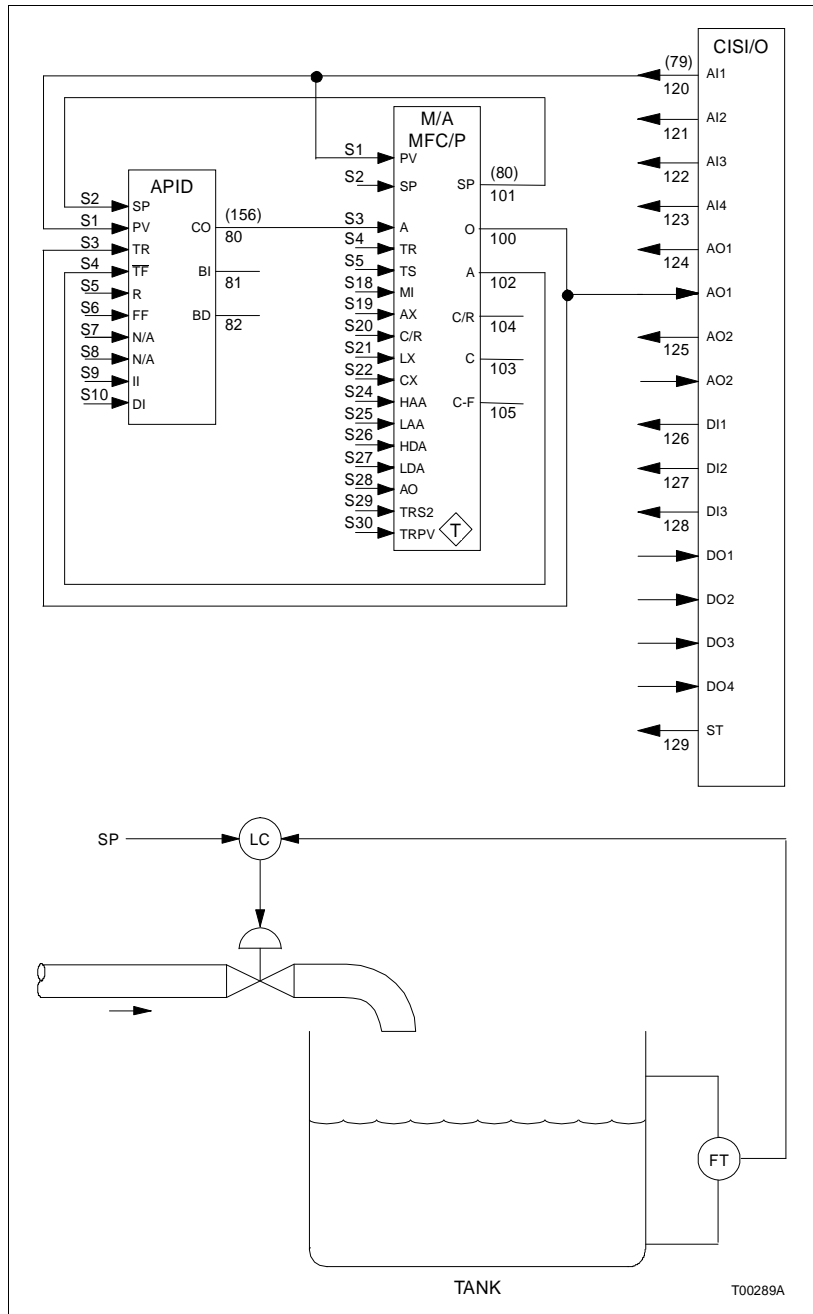

Figure 2-4. Basic Station Configuration

modes. When the SAC station transfers to manual operation from cascade, it enters manual basic operation. Figure 2-5 shows an example of how function code 80 generates a cascade set point from an external variable.

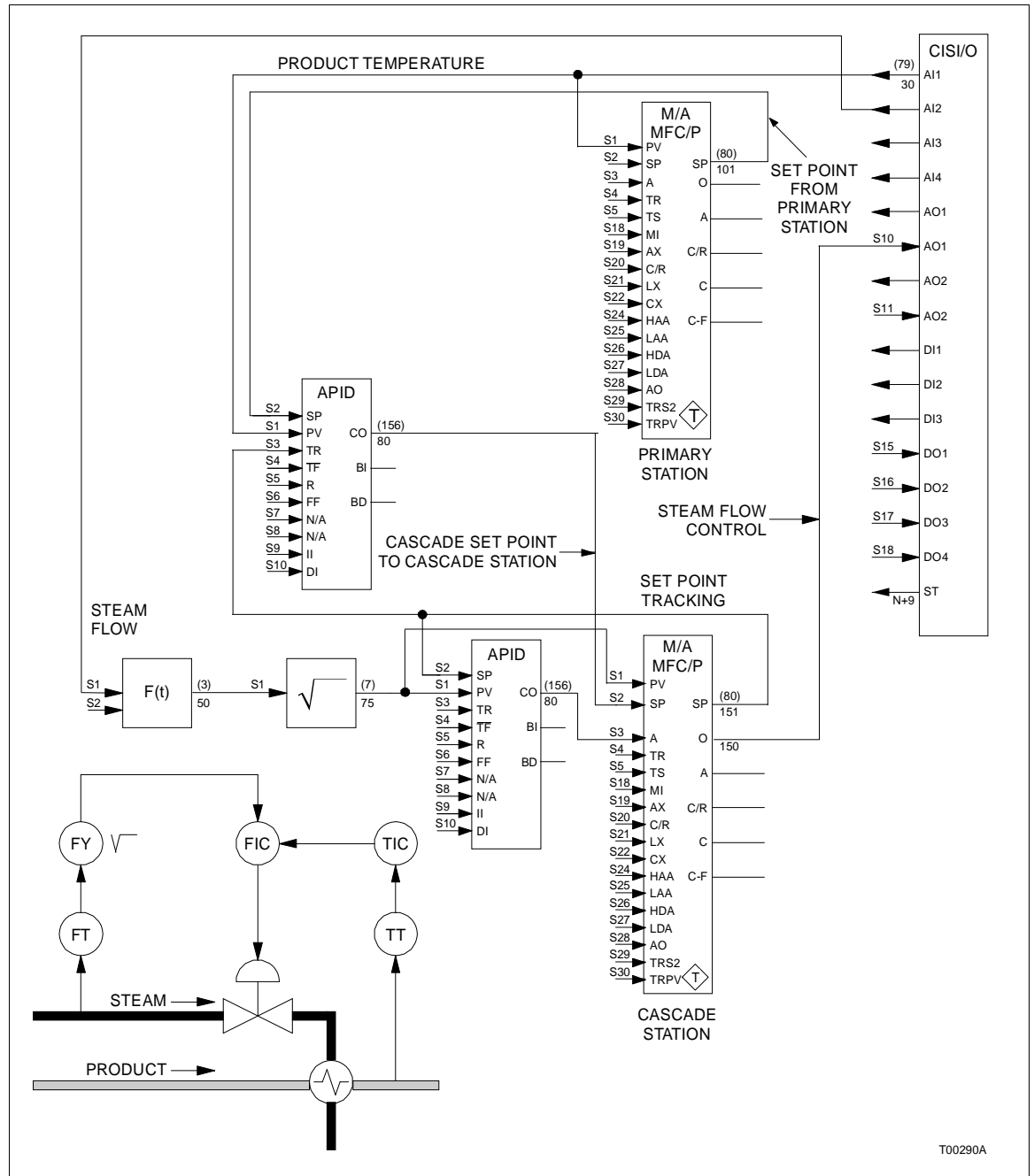

Figure 2-5. Module Configuration with Cascade Set Point from External Source

Ratio Station

A variable controlled by another process variable determines the set point for a ratio station. The MFP module calculates the set point by multiplying the wild variable by a ratio index set in function code 80. The operator can change the ratio index through the set raise/lower pushbutton. By changing the ratio index, the operator changes the set point ratio that the control algorithm uses to calculate the set point. When the SAC station transfers to manual operation from automatic ratio operation, it goes into manual basic operation. Figure 2-6 shows an example ratio station.

While in ratio mode, the bar graph indicates the value of the set point while the alphanumeric indicates the ratio index. The

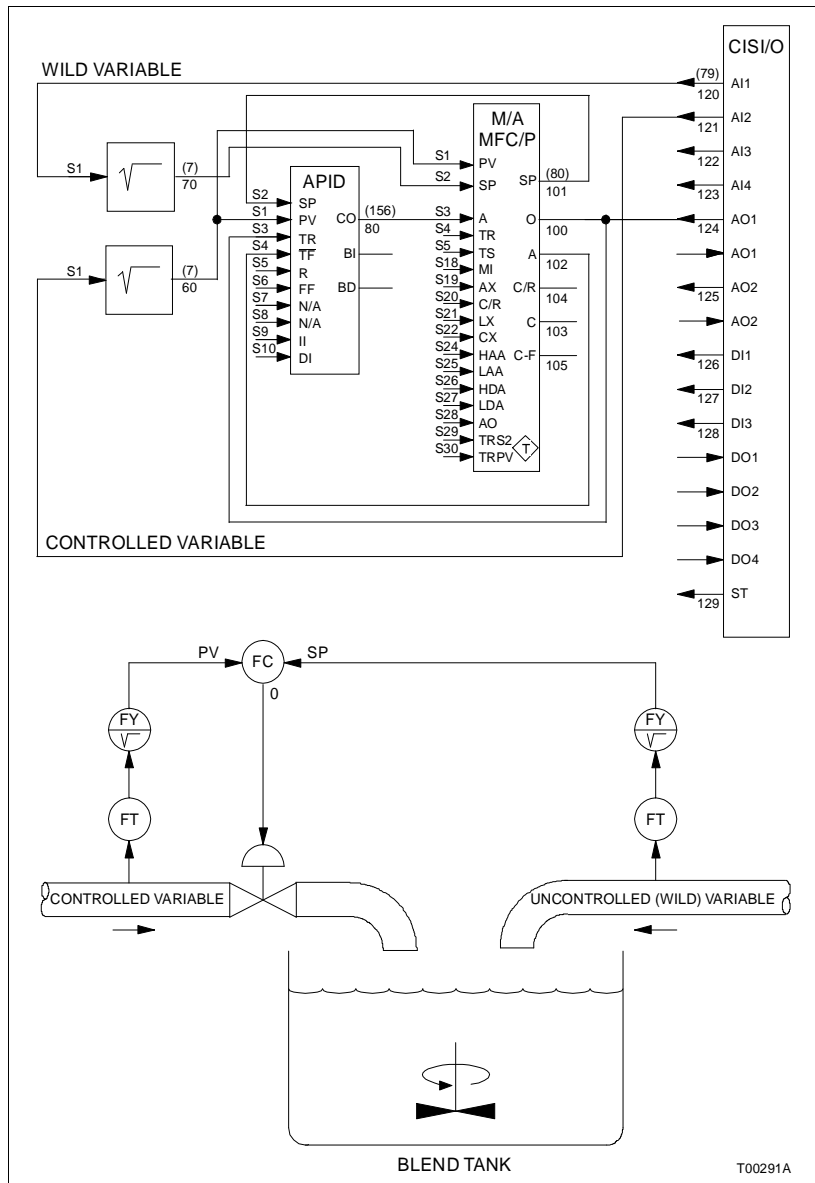

Figure 2-6. Ratio Station Configuration

ratio index has a range from zero to 100. If the set point track specification of function code 80 is set, the ratio index value remains fixed until the set point track is disabled.

### SAC STATION I/O CIRCUITRY

The analog control station interfaces an MFP module to a process. Its circuitry provides process monitoring and hard station control in parallel with a CIS module. The eight blocks that make up the functional operation of SAC circuitry are (see Figure 2-7):

- Microprocessor and support circuitry.
- Serial interface.
- Faceplate components and display driver.

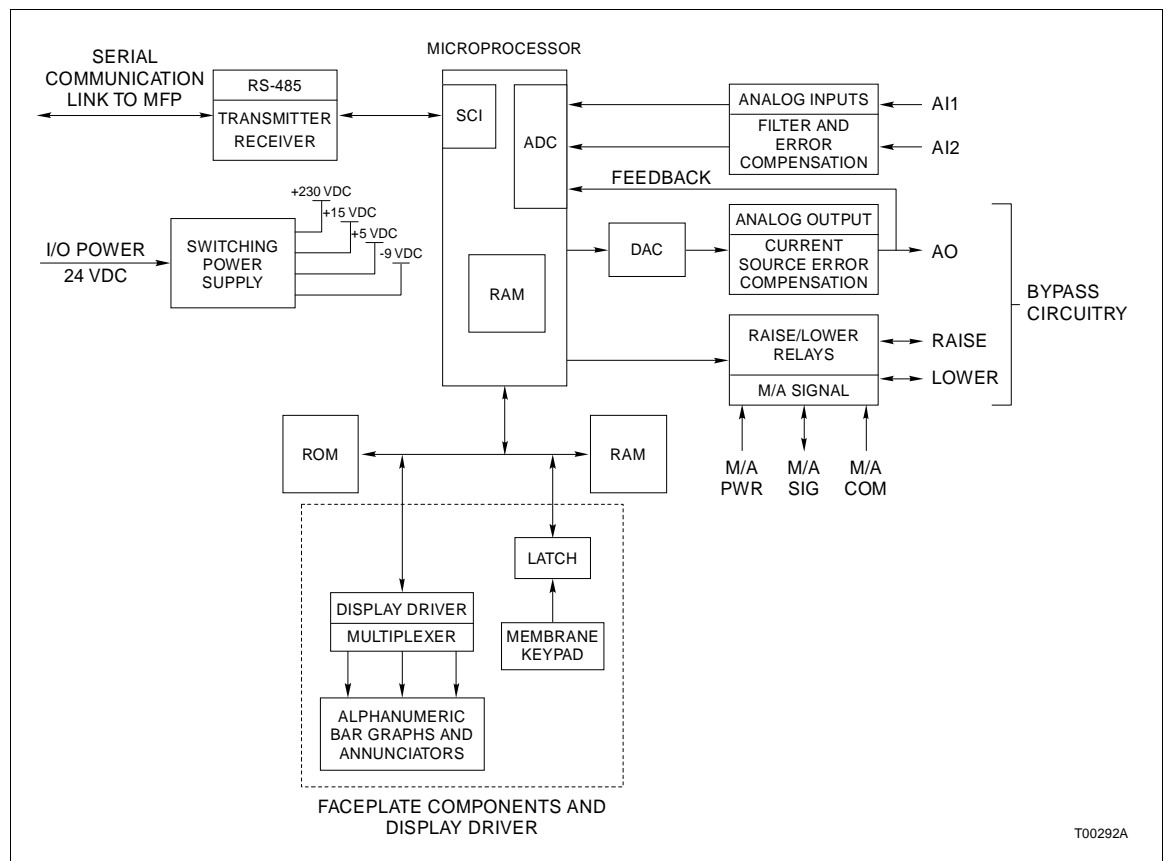

Figure 2-7. Block Diagram of SAC Station Circuitry



- Bypass circuitry.
- Electric drive circuitry.
- Analog output circuitry.
- Analog input circuitry.
- Switching power supply.

The microprocessor provides the station with intelligence and communication capability. It supports one serial port, a four-channel A/D conversion, general I/O lines, and an address/data bus that interfaces the microprocessor to memory and peripheral devices. There is also a built-in machine fault timer (MFT) function. This halts the station if the software fails to write to the timer every 1.5 seconds. The microprocessor provides a serial interface that enables it to send set point and control output data, and receive update messages through the RS-485 port to the MFP module.

Feedback from the analog input passes through a 60-hertz filter, differential amplifier and error compensation amplifier before it reaches the microprocessor. The microprocessor has an internal analog to digital converter (A/D conversion) that converts the analog inputs to a digital word. The microprocessor may use this information to update displays or send to the MFP module in a station update message.

The bypass circuit is a microprocessor controlled four to 20-milliamp analog output that provides analog output backup for the CIS outputs. This circuitry also puts an electric drive in manual operation if raise/lower (R/L) contact control is desired. Electric drive circuitry contains two relays that provide contact outputs for the electric drive raise/lower signals. Membrane pushbuttons control the electric drive relays directly.

The display driver continuously updates the faceplate displays with system process information from the MFP module (through the serial interface), process variable, control output, set point, operational mode and error status.

---

### ***Bypass Circuitry***

Bypass circuitry on the analog control station interfaces to the CIS analog output or electric drive. The SAC station bypass circuitry provides five bypass functions. Refer to Table 2-1 for a list of the five bypass functions and a brief description.

In normal mode of operation, the station analog output matches the last received control output value from the MFP module. The station analog output is a closed loop controlled current source with the output shunted to ground by Q1 (see Figure 2-8). The

Table 2-1. Bypass Circuit Functions and Specifications

| Function             | Purpose   | Specification  |
|----------------------|---|--|
| Analog input         | Monitors position feedback or any external analog signal.                                     | Differential: 0.75 to 5.25 V   |
| Analog output        | Position control.   | 3 to 21 mA<br>0 to 600 Ω max load impedance<br>8-bit resolution        |
| CIS override         | Electronically disconnects AO of CIS and station takes control.                               | N/A  |
| M/A select           | Controls drive mode to raise/lower contacts. In auto, the drive uses analog position control. | UE drive: 40 mA sink, 0.1 V drop<br>RW drive: 40 mA source, 0.1 V drop |
| Raise/lower contacts | Jogging position control.   | 24 VDC, 100 mA   |

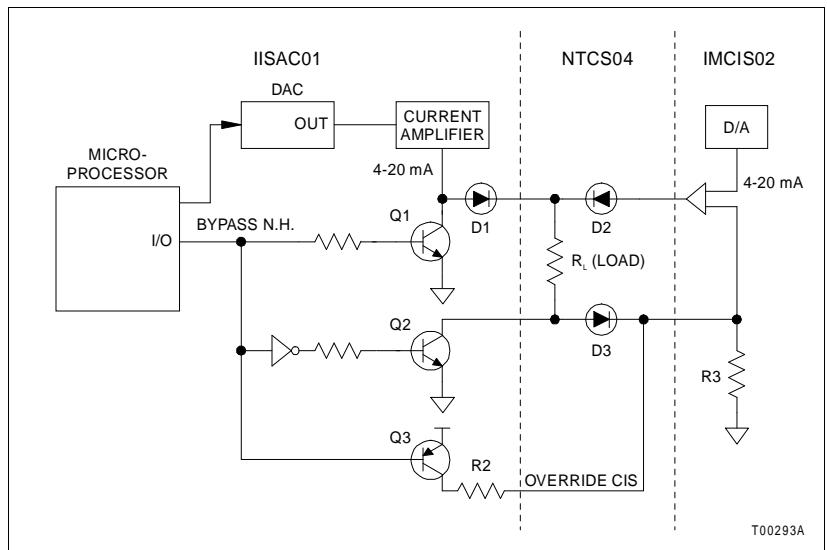

Figure 2-8. Station Bypass Circuitry

station remains in this state until forced into manual override or bypass mode of operation. At this time, the station will turn the CIS module analog output off and drive the load. If electric drive option is enabled, the station will not drive the analog output. The station will turn on the electric drive control signal (M/A\_SELECT) which forces the drive to respond only to contact inputs.

Either the CIS module or the SAC station output can drive the analog output on a termination unit. The bypass circuitry on the SAC station and termination unit determine if the CIS module or SAC station output is the source of the output to the load (see Figure 2-8). During normal operation, the bypass normally high (BYPASS N.H.) signal is a logic one which turns Q1

on, reverse biasing D1 and turns Q2 and Q3 off. Q1 sinks the SAC station output to ground and the CIS module output drives the load through D2 and D3. In bypass or manual override, the BYPASS N.H. signal is a logic zero. This state causes Q1 to turn off while Q2 and Q3 turn on. D1 is now forward biased, allowing the SAC station to source the output current to  $R_L$ . With Q3 on, the R2/R3 voltage divider reverse biases D3 which disconnects the CIS analog output from the load.

---

### **Electric Drive Circuitry**

The electric drive circuit provides both relay contact outputs and transfer signal (M/A\_SELECT) to both universal and RW electric drives. Dipswitch SW2 position three enables this option, and the position of jumper JP2 determines drive selection. This circuit is operational only in stand-alone, bypass and manual override modes of operation. Terminal blocks one and four of the NTCS04 termination unit and terminal block one of the NIDS01 Station Termination Module contain all the field wiring for the drives (refer to Table 2-1).

There are three stand-alone mode display options and three bypass mode display options that determine how the display operates when the station is in electric drive mode. For more information on display options refer to Section 3.

Figure 2-9 shows the electric drive circuit. The electric drive circuit is powered from the terminal block connected by either the system I/O supply or an external power source (24 VDC). The power supply designator at the termination units and termination modules are M/A\_PWR and M/A\_COM. Providing power supply inputs independent from the I/O supply allows the electric drive circuit to be powered from a secured source. If the I/O supply fails, the relay K1 de-energizes. This connects the M/A\_PWR and M/A\_COM inputs across the series circuit of the raise/lower faceplate membrane switches and relays. Pressing the membrane switches causes the electric drive to change positions.

The SAC station microcontroller and interlocking relay contacts control the electric drive circuit operation. Upon application of power, the station goes through an initialization cycle. During initialization the microcontroller deciphers the user selectable options. During the initialization cycle, the microprocessor will not assert any control signals. With transistor Q1 turned off, relay K1 is de-energized. This causes the M/A\_SELECT signal to be asserted and allows the raise/lower relays to be controlled by the raise/lower membrane pushbuttons.

The sense of the M/A\_SELECT signal is determined by jumper JP2. In stand-alone mode the microprocessor takes control of

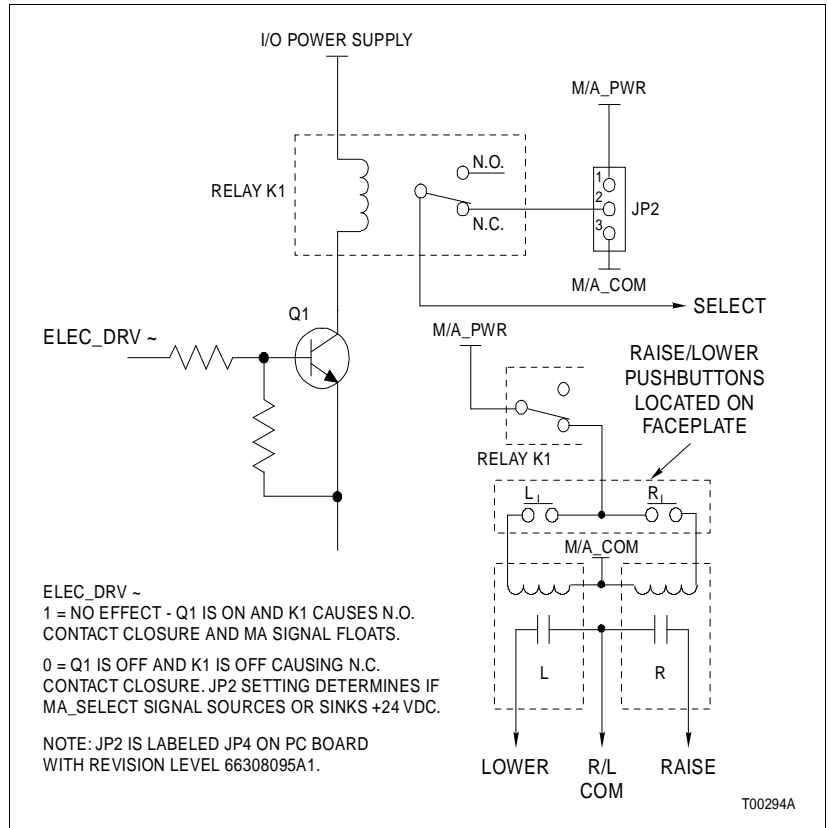

Figure 2-9. Electric Drive Circuit

all the station's I/O circuits. Control signals (e.g., ELEC\_DRV~) are asserted to the proper state as defined by the user selectable option dipswitches. If the electric drive option is enabled, ELEC\_DRV~ is asserted low, transistor Q1 is off and relay K1 is de-energized. With K1 de-energized, pressing the raise/lower membrane pushbutton causes the associated raise/lower relay to energize closing the contact output, which jogs the electric drive. If the option is disabled, ELEC\_DRV~ will be asserted high, causing Q1 to turn on and energizing relay K1. When K1 is energized, the M/A\_SELECT signal goes to an open circuit and the series circuit powered from the M/A\_PWR and M/A\_COM inputs open. This disables the raise/lower contact outputs.

When the SAC station exits electric drive bypass/manual override mode to normal mode operation, the new value for control output will be the value of the analog input as defined in the column of Tables 3-8 and 3-9 labeled action on control output. At the time of transfer, either AI1 or AI2 will become the control output value written to the CIS module. Normally, AI1 is the position feedback from the device and AI2 is the process variable. For more information on electric drive operation refer to [Section 3](#).

### Analog Output Circuitry

Figure 2-10 shows a schematic of the analog output circuit. The microprocessor sends the desired control output value to a digital to analog converter (DAC). The DAC generates a corresponding zero to five VDC signal (VDAC). The VDAC signal is the set point for the current loop error amplifier. The current loop amplifier drives Q1 as required to cause current flow through R1 which develops a corresponding voltage drop equal to VDAC. The voltage across R1 is buffered by a differential amplifier and is routed to the current error amplifier as the negative feedback signal required to form a closed servo loop. This closed loop system provides a constant current to the load.

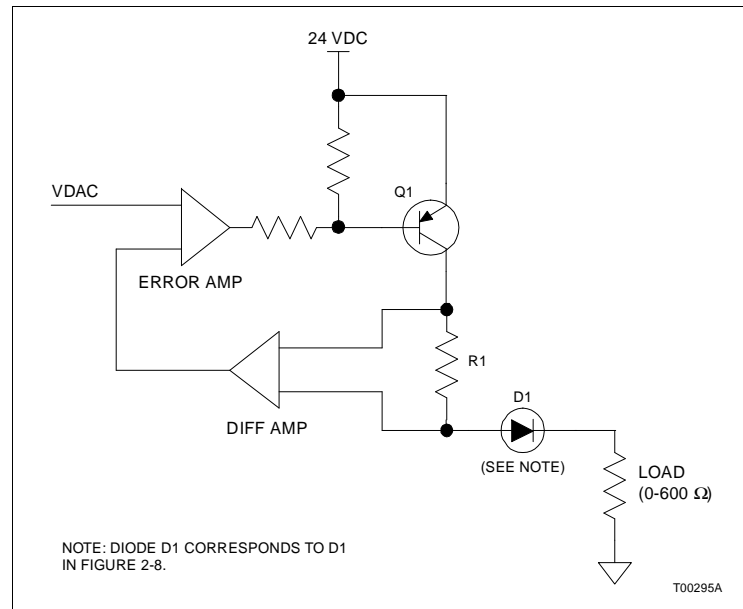

Figure 2-10. Analog Output Circuitry

### Analog Input Circuitry

The SAC station has two analog inputs (AI) available. One of the analog inputs usually monitors position feedback from the output device. The other input can be an additional feedback signal or another process variable in the control loop. The input can be a system powered current input, externally powered input current (four to 20 milliamps), single ended voltage (one to five VDC) or differential voltage. Dipshunt settings on the TCS termination unit set the input type.

The analog input circuit prepares the analog signal and makes it compatible with the microprocessor. It first passes through a 60-hertz filter, high impedance buffer amplifier, and differential amplifier. The output of the differential amplifier passes through an error compensation circuit. This circuit takes the 0.75 to 5.25 VDC input and changes it to a corresponding zero

to five VDC level. An on-board analog to digital converter (ADC) translates this zero to five VDC signal to a digital value.

Analog input two has a square root display option. When enabled (dipswitch SW4, position one), it takes the square root of the zero to 100 percent input signal. This signal is then multiplied by a gain of ten for a new zero to 100 percent value. This signal conditioning is only used by the station for display purposes.

---

## SECTION 3 - INSTALLATION

---

### *INTRODUCTION*

This section explains how to prepare and install the IISAC01 Analog Control Station (SAC). It explains how to select and set the station options, mount the station housing, install the termination unit or termination module and cable, insert and remove the station, and configure the module.

---

### *SPECIAL HANDLING*

Observe these steps when handling electronic circuitry:

**NOTE:** Always use Bailey Controls field static kit (part number 1948385A1 - consisting of two wrist straps, ground cord assembly, alligator clip, and static dissipative work surface) when working with the modules. The kit grounds a technician and the static dissipative work surface to the same ground point to prevent damage to the modules by electrostatic discharge.

1. **Use Static Shielding Bag.** Keep the modules in the static shielding bag until you are ready to install them in the system. Save the bag for future use.
2. **Ground Bag Before Opening.** Before opening a bag containing an assembly with semiconductors, touch it to the equipment housing or a ground to equalize charges.
3. **Avoid Touching Circuitry.** Handle assemblies by the edges; avoid touching the circuitry.
4. **Avoid Partial Connection of Semiconductor.** Verify that all devices connected to the modules are properly grounded before using them.
5. **Ground Test Equipment.**
6. **Use an Antistatic Field Service Vacuum.** Remove dust from the module if necessary.
7. **Use a Grounded Wrist Strap.** Connect the wrist strap to the appropriate grounding plug on the power entry panel. The grounding plug on the power entry panel is connected to the earth grounding electrode system through the AC safety ground.
8. **Do Not Use Lead Pencils to Set Dipswitches.** To avoid contamination of dipswitch contacts that can result in unnecessary circuit board malfunction, do not use a lead pencil to set a dipswitch.

**UNPACKING AND INSPECTION**

The SAC station is carefully packed to protect it during shipping. Read the following information about handling before inspecting the SAC station.

1. Examine the hardware immediately to verify that it has not been damaged in transit.
2. Notify the nearest Bailey Controls sales office of any such damage.
3. File a claim for any damage with the transportation company that handled the shipment.
4. Use the original packing material and container to store the hardware.
5. Store the hardware in an environment of good air quality, free from temperature and moisture extremes.

**SELECTING OPTIONS**

There are four dipswitches and three jumpers on the SAC station circuit board that must be configured before placing the station into operation. Set all option dipswitches so that the station operates properly within the process control strategy. Figure 3-1 shows the location of the option dipswitches and

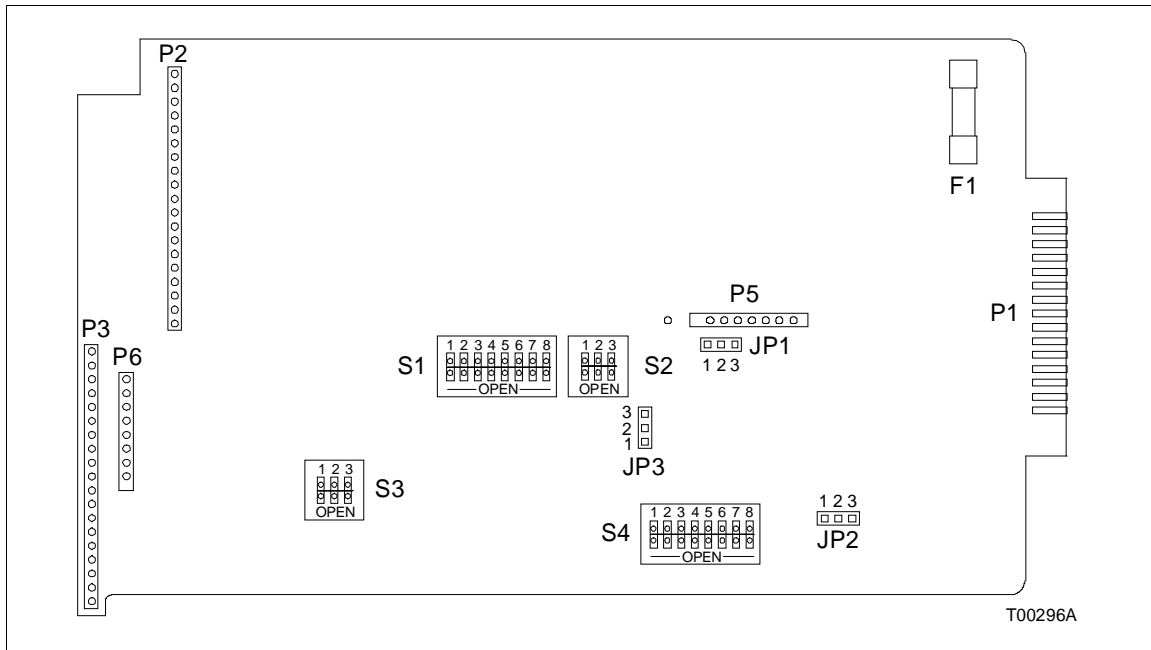

Figure 3-1. Dipswitch and Jumper Locations on the SAC Station Circuit Board



jumpers on the station circuit board. Tables 3-1 through 3-7 show the SAC station dipswitch and jumper settings.

**Diagnostics (SW1, Position 1)**

The diagnostics setting (dipswitch SW1, position one) is used only by the factory. Check this dipswitch setting and verify that it is in the correct position for normal operation. The SAC station will not operate normally in the diagnostics setting. To check this dipswitch setting:

1. Refer to Table 3-1 for the dipswitch setting required for normal operation.
2. Verify that the dipswitch is set for normal operation.

Table 3-1. Dipswitch SW1 Positions 1 and 2

| Option             | Position |   | Description                          | User Setting |
|--------------------|----------|---|--------------------------------------|--------------|
|                    | 1        | 2 |                                      |              |
| Diagnostics        | 1        |   | Enable diagnostics. Do not use.      | 0            |
|                    | 0        |   | Normal operation.                    |              |
| Communication rate |          | 1 | Enable 40 kbaud (>8 stations).       |              |
|                    |          | 0 | Enable 5 kbaud (8 stations maximum). |              |

NOTES: 0 = CLOSED or ON, 1 = OPEN or OFF. Shaded area denotes default setting.

**Communication Rate (SW1, Position 2)**

The SAC station communicates with the module in two baud rates. The baud rate must match the module capability. The baud rate determines how many stations can reside on one serial link. Select the communication rate (five or 40 kilobaud) for the RS-485 communication port that matches the communication rate of the module. The baud rate of the controller module and MFC module are fixed at five kilobauds. The MFP module needs to have specification S3 of function code 90 set for the desired baud rate. The default baud rate is five kilobauds. To select 40 kilobauds, add 100 to S3 of block 20, function code 90 (e.g., 100 or 101). To select the communication rate:

**NOTE:** Only the IMMFP03 Multi-Function Processor Module or IMMFP01 and IMMFP02 module with revision level C.0 or higher firmware have 40-kilobaud communication rates.

1. Determine the communication rate for your application (5 or 40 kilobaud).

2. Refer to Table 3-1 and set SW1, position 2 for the desired communication rate and record the dipswitch setting in the space provided in Table 3-1.

---

**Station Address (SW1, Positions 3 through 8)**

Each station must have a unique address. A SAC station (configured for 40 kilobaud communication rate) can have any address from zero to 63 when supported by an IMMFP01 or IMMFP02 module revision C.0 firmware or higher or an IMMFP03 module. All other modules (COM, QRC, MFC and MFP modules with revision A or B firmware) can support up to eight stations at five-kilobaud communication rate. Use addresses zero to seven when using these modules. To set the SAC station address:

1. Refer to Table 3-2 for examples of address settings.
2. Select an address (in applications having multiple SAC stations, each station must have a different address). SAC stations using the 5-kilobaud serial communication link must use addresses 0 through 7. Stations using the 40-kilobaud serial communication link can use any address from 0 to 63.
3. Set the station address and record it in the space provided in Table 3-2.

*Table 3-2. Dipswitch SW1 Address Positions 3 through 8*

| Address Example | Dipswitch Position (Binary Value) |        |       |       |       |       |
|-----------------|-----------------------------------|--------|-------|-------|-------|-------|
|                 | 3 (32)                            | 4 (16) | 5 (8) | 6 (4) | 7 (2) | 8 (1) |
| 0               | 0                                 | 0      | 0     | 0     | 0     | 0     |
| 16              | 0                                 | 1      | 0     | 0     | 0     | 0     |
| 32              | 1                                 | 0      | 0     | 0     | 0     | 0     |
| 48              | 1                                 | 1      | 0     | 0     | 0     | 0     |
| 63              | 1                                 | 1      | 1     | 1     | 1     | 1     |
| User Settings   |                                   |        |       |       |       |       |
|                 |                                   |        |       |       |       |       |
|                 |                                   |        |       |       |       |       |

NOTE: 0 = CLOSED or ON, 1 = OPEN or OFF.

---

**Auto Bypass (SW2, Position 1)**

This option setting determines what mode of operation the station will transfer to if a communication failure occurs. Auto bypass automatically places the station in the bypass mode when a communication failure occurs. With auto bypass

disabled, the station enters the stand-alone mode upon a module communication failure. To set the auto bypass option:

1. Refer to Table 3-3 for dipswitch SW2, position 1 settings.
2. Set dipswitch SW2, position 1 to enable or disable the auto bypass option and record the dipswitch setting in the space provided in Table 3-3.

Table 3-3. Dipswitch SW2 Positions 1 through 3

| Option         | Position |   |   | Description            | User Setting |
|----------------|----------|---|---|------------------------|--------------|
|                | 1        | 2 | 3 |                        |              |
| Auto bypass    | 1        |   |   | Enable auto bypass     |              |
|                | 0        |   |   | Disable auto bypass    |              |
| Demand output  |          | 1 |   | Reverse demand output  |              |
|                |          | 0 |   | Normal demand output   |              |
| Electric drive |          |   | 1 | Enable electric drive  |              |
|                |          |   | 0 | Disable electric drive |              |

NOTE: 0 = CLOSED or ON, 1 = OPEN or OFF.

---

### ***Demand Output (SW2, Position 2)***

The reverse demand output option reverses the current of the demand output in bypass mode (low bar graph at zero percent equals 20 milliamps, high bar graph at 100 percent equals four milliamps). The module configuration performs this function in normal mode. To set the reverse demand output:

1. Determine if your application requires reverse or normal demand output.
2. Refer to Table 3-3 for dipswitch SW2, position 2 settings.
3. Set dipswitch SW2, position 2 for reverse or normal demand output and record the dipswitch setting in the space provided in Table 3-3.

---

### ***Electric Drive Option (SW2, Position 3 and JP2)***

This option is active when the SAC station is in stand-alone, bypass or manual override mode. With this option enabled, the SAC station asserts the signal M/A select at the termination unit forcing the electric drive to accept raise/lower contact outputs only. This option requires setting one dipswitch position and one jumper position to enable the electric drive option and select the drive type. Disabling this option causes the station analog output to operate as a standard four to 20-milliamp

control output in manual override or bypass operation. To enable the electric drive option:

1. Determine the drive type required for your application.
2. See Figure 3-1 for the location of JP2 and dipswitch SW2.
3. Refer to Table 3-3 for the dipswitch SW2, position 3 settings.
4. Set dipswitch SW2, position 3 to enable the electric drive and record the setting in the space provided in Table 3-3.
5. Refer to Table 3-4 for the JP2 jumper setting.
6. Set JP2 for the electric drive type and record the jumper setting in the space provided in Table 3-4.

**NOTE:** Dipswitch SW2, position 3 must be in the disable position when using the standard analog output in bypass operation (refer to Table 3-3). There are 3 stand-alone mode display options and 3 bypass mode display options available when using the electric drive option. Only IISAC01 Analog Control Stations that are firmware revision B.3 or higher have these options.

Table 3-4. SAC Station Jumper Settings

| Option                          | Jumper | Setting | Option Status                  | User Setting |
|---------------------------------|--------|---------|--------------------------------|--------------|
| Manual override switch          | JP1    | 1 - 2   | Enable manual override switch  |              |
|                                 |        | 2 - 3   | Disable manual override switch |              |
| Electric drive type             | JP2    | 1 - 2   | RW drive (active high)         |              |
|                                 |        | 2 - 3   | Universal drive (active low)   |              |
| Microcomputer mode of operation | JP3    | 1 - 2   | Normal operation               | 1 - 2        |
|                                 |        | 2 - 3   | Factory setting                |              |

**NOTE:** Shaded area denotes default setting.

## DISPLAY OPTIONS

The SAC station has three distinct display operating modes: stand-alone, bypass/manual override and normal. The AI1 and AI2 designators should not be confused with the physical analog input to the termination device. Each operating mode display option is selected independently of the other modes. Tables 3-5, 3-6, and 3-7 define the display options. Tables 3-8 and 3-9 show the electric drive mode display options. Table 3-10 defines the relationship of termination device analog inputs to SAC station analog input designators.

Selection of an analog input for display purposes also enables the error detection function. A failure of a selected analog input

causes an error code to appear on the alphanumeric display regardless of the present operating mode display options.

**NOTE:** Analog inputs AI1 and AI2 are not available with the ICS termination module. AI1 may be displayed with the ICS/IDS pair. AI2 is not available with the ICS/IDS pair.

**Stand-Alone Mode Display Options (SW3)**

Set dipswitch SW3 to select the faceplate display operation when the station is in the stand-alone mode. Section 4 explains faceplate display operation. Table 3-5 lists the stand-alone display options and dipswitch settings available with revision B.3 firmware SAC stations. To set the stand-alone display options:

1. Determine the stand-alone display options required for your application.
2. Refer to Table 3-5 for the display options and their dipswitch settings.
3. Set to enable the desired display options and record the dipswitch settings in the space provided in Table 3-5.

Table 3-5. Dipswitch SW3 Positions 1 through 3

| Display Option   | Position |   |                | VAR              | SET   | OUT                                | ALPHA           | User Setting |
|------------------|----------|---|----------------|------------------|-------|------------------------------------|-----------------|--------------|
|                  | 1        | 2 | 3              |                  |       |                                    |                 |              |
| Stand-alone mode | 0        | 0 | 0              | Blank            | Blank | Blank                              | DO              |              |
|                  | 0        | 0 | 1 <sup>1</sup> | Blank            | Blank | AI1 <sup>2</sup>                   | DO <sup>3</sup> |              |
|                  | 0        | 1 | 0              | Blank            | Blank | AI1 <sup>2</sup> / DO <sup>4</sup> | Blank / DO      |              |
|                  | 0        | 1 | 1              | AI1 <sup>2</sup> | Blank | Blank                              | DO              |              |
|                  | 1        | 0 | 0              | Blank            | Blank | DO                                 | DO              |              |
|                  | 1        | 0 | 1              | AI1 <sup>2</sup> | Blank | DO                                 | DO              |              |
|                  | 1        | 1 | 0 <sup>1</sup> | AI2 <sup>5</sup> | Blank | AI1 <sup>2</sup>                   | DO <sup>3</sup> |              |
|                  | 1        | 1 | 1 <sup>1</sup> | AI2 <sup>5</sup> | Blank | DO <sup>3</sup>                    | DO <sup>3</sup> |              |

- NOTES:** 0 = CLOSED or ON, 1 = OPEN or OFF.
1. Only display options available when electric drive option is enabled. Refer to Table 3-8 for action on control output information.
  2. Only available when using termination units or NIDS01 termination modules.
  3. Display is blanked when electric drive option is enabled.
  4. VAR dipswitch toggles the display from AI1 to DO.
  5. Only available when using termination units, not termination modules.

**Square Root Enable (SW4, Position 1)**

This option enables the square root function on the second analog input (AI2). With this option enabled, the station converts the value of AI2 to a value based on ten times the square

root of AI2. This value is displayed as zero to 100 percent. To set the square root option:

1. Refer to Table 3-6 for the dipswitch SW4, position 1 dipswitch setting.
2. Set dipswitch SW4, position 1 to enable or disable the square root option and record the dipswitch setting in the space provided in Table 3-6.

Table 3-6. Dipswitch SW4 Position 1

| Display Option         | Position 1 | Description                        | User Setting |
|------------------------|------------|------------------------------------|--------------|
| Square root (AI2 only) | 1          | Enable square root display option  |              |
|                        | 0          | Disable square root display option |              |

NOTE: 0 = CLOSED or ON, 1 = OPEN or OFF.

---

**Normal Mode Display Options (SW4, Positions 2, 3 and 4)**

Set dipswitch SW4, positions two, three and four to select the faceplate display operation when the SAC station is in the normal mode. Table 3-7 lists the normal mode display options and dipswitch settings with revision B.3 firmware SAC stations. To set the normal mode display options:

1. Determine the normal mode display options required for your application.
2. Refer to Table 3-7 for the dipswitch settings of the options selected.
3. Set SW4, positions 2 through 4 to the positions that enable the desired display options and record the dipswitch settings in the space provided in Table 3-7.

---

**Bypass/Manual Override Mode Display Options (SW4, Positions 5, 6, 7 and 8)**

Set dipswitch SW4, positions five through eight to select the faceplate display operation when the SAC station is in the bypass/manual override mode of operation. Table 3-7 lists the bypass/manual override mode display options and dipswitch settings available with revision B.3 firmware SAC stations. To set the bypass/manual override mode display options:

1. Determine the bypass/manual override mode display options required for your application.
2. Refer to Table 3-7 for the dipswitch settings of the options selected.

3. Set dipswitch SW4, positions 5 through 8 to the positions that enable the desired display options and record the dipswitch settings in the space provided in Table 3-7.

Table 3-7. Dipswitch SW4 Positions 2 through 8

| Display Options                 | Position |   |   |   |   |                |                  | VAR <sup>1</sup> | SET   | OUT              | ALPHA <sup>1</sup>   | User Setting |
|---------------------------------|----------|---|---|---|---|----------------|------------------|------------------|-------|------------------|----------------------|--------------|
|                                 | 2        | 3 | 4 | 5 | 6 | 7              | 8                |                  |       |                  |                      |              |
| Normal mode                     | 0        | 0 | 0 |   |   |                |                  | PV               | SP    | CO               | PV, SP, CO           |              |
|                                 | 0        | 0 | 1 |   |   |                |                  | PV               | SP    | AI1 <sup>2</sup> | PV, SP, CO           |              |
|                                 | 0        | 1 | 0 |   |   |                |                  | PV               | SP    | Blank            | PV, SP, CO           |              |
|                                 | 0        | 1 | 1 |   |   |                |                  | PV               | SP    | All on           | PV, SP, CO           |              |
|                                 | 1        | 0 | 0 |   |   |                |                  | AI2 <sup>3</sup> | SP    | CO               | PV, SP, CO           |              |
|                                 | 1        | 0 | 1 |   |   |                |                  | AI2 <sup>3</sup> | SP    | AI1 <sup>2</sup> | PV, SP, CO           |              |
|                                 | 1        | 1 | 0 |   |   |                |                  | AI2 <sup>3</sup> | SP    | Blank            | PV, SP, CO           |              |
|                                 | 1        | 1 | 1 |   |   |                |                  | AI2 <sup>3</sup> | SP    | All on           | PV, SP, CO           |              |
| Manual override/<br>bypass mode |          |   |   | 0 | 0 | 0              | 0 <sup>4</sup>   | Blank            | Blank | AI1 <sup>2</sup> | DO <sup>5</sup>      |              |
|                                 |          |   |   | 0 | 0 | 0              | 1                | Blank            | Blank | DO               | DO                   |              |
|                                 |          |   |   | 0 | 0 | 1              | 0                | AI1 <sup>2</sup> | Blank | DO               | DO                   |              |
|                                 |          |   |   | 0 | 0 | 1              | 1                | DO               | Blank | DO               | DO                   |              |
|                                 |          |   |   | 0 | 1 | 0              | 0                | DO               | Blank | AI1 <sup>2</sup> | DO                   |              |
|                                 |          |   |   | 0 | 1 | 0              | 1 <sup>4</sup>   | AI2 <sup>3</sup> | Blank | AI1 <sup>2</sup> | DO <sup>5</sup>      |              |
|                                 |          |   |   | 0 | 1 | 1              | 0                | AI2 <sup>3</sup> | Blank | DO               | DO                   |              |
|                                 |          |   |   | 0 | 1 | 1              | 1                | PV <sup>6</sup>  | Blank | AI1 <sup>2</sup> | PV <sup>6</sup> , DO |              |
|                                 |          |   |   | 1 | 0 | 0              | 0                | PV <sup>6</sup>  | Blank | DO               | PV <sup>6</sup> , DO |              |
|                                 |          |   | 1 | 0 | 0 | 1 <sup>4</sup> | AI2 <sup>3</sup> | Blank            | Blank | DO <sup>5</sup>  |                      |              |

NOTES: 0 = CLOSED or ON, 1 = OPEN or OFF.

1. PV displayed is the S1 input to function code 21, 22, 23 or 80. It applies to all indications of PV on the display.
2. Only available when using termination units or NIDS01 termination modules.
3. Only available when using termination units, not termination modules.
4. Only display options available when electric drive option is enabled. Refer to Table 3-9 for action on control output information.
5. Display is blanked when electric drive option is enabled.
6. Upon loss of communication, last known value is displayed.

### Manual Override (JP1)

Manual override gives the operator hard, open loop control of the process directly from the station. While in this mode, the station ignores all module requests to transfer to other operation modes. This option setting enables or disables the manual override slide switch behind the legend door. When disabled, the station interprets the M/A switch as always being in the **A** automatic mode. To enable the manual override switch:

1. Refer to Table 3-4 for JP1 jumper settings.

2. Set JP1 to enable or disable manual override switch and record the jumper setting in the space provided in Table 3-4.

**ELECTRIC DRIVE MODE DISPLAY OPTIONS (SW3 AND SW4)**

There are three stand-alone mode display options and three bypass/manual override mode display options that determine how the display operates when the station is in electric drive mode. Tables 3-8 and 3-9 show the electric drive mode display options action on control outputs. Tables 3-5, 3-6, and 3-7 summarize those display options. Refer to Tables 3-5, 3-6, and 3-7 for information on setting the stand-alone and bypass/manual override display options. The display options apply to SAC stations with firmware revision B.3 or higher. To set the electric drive mode display option:

1. Determine the electric drive mode display options required for your application.
2. Refer to Tables 3-5, 3-6, and 3-7 for the required stand-alone or bypass/manual override mode dipswitch setting that select the desired options.
3. Set the display options by referring to Tables 3-5, 3-6, and 3-7 for the dipswitch position that enable the desired display options and record the switch setting in the space provided.

*Table 3-8. Dipswitch SW3 Electric Drive Mode Display Options*

| Stand-Alone Display Mode |   |   |                   |       |                          |
|--------------------------|---|---|-------------------|-------|--------------------------|
| Position                 |   |   | Bar Graph Display |       | Action On Control Output |
| 1                        | 2 | 3 | VAR               | OUT   |                          |
| 0                        | 0 | 1 | Blank             | AI1   | AI1 to CO                |
| 1                        | 1 | 0 | AI2               | AI1   | AI1 to CO                |
| 1                        | 1 | 1 | AI2               | Blank | AI2 to CO                |

*Table 3-9. Dipswitch SW4 Electric Drive Mode Display Options*

| Manual Override/Bypass Display Mode |   |   |   |                   |       |                          |
|-------------------------------------|---|---|---|-------------------|-------|--------------------------|
| Position                            |   |   |   | Bar Graph Display |       | Action On Control Output |
| 5                                   | 6 | 7 | 8 | VAR               | OUT   |                          |
| 0                                   | 0 | 0 | 0 | Blank             | AI1   | AI1 to CO                |
| 0                                   | 1 | 0 | 1 | AI2               | AI1   | AI1 to CO                |
| 1                                   | 0 | 0 | 1 | AI2               | Blank | AI2 to CO                |



When the station exits electric drive bypass mode to normal mode operation, the new control output value is the value of the analog input as defined in Tables 3-8 and 3-9. At the time of transfer, either AI1 or AI2 becomes the control output in normal mode. Normally, AI1 is the position feedback from the device and AI2 is the process variable.

---

### **MICROCOMPUTER MODE OF OPERATION (JP3)**

Microcomputer mode of operation jumper settings determine the internal configuration of the microprocessor. Factory technicians use this option setting during factory testing of the station; do not use it during normal operation. For normal operation, JP3 must be shorted across pins one and two. Table 3-4 shows the jumper settings for this option.

---

### **MOUNTING THE STATION HOUSING**

The housing for the SAC station is designed for conventional panel board mounting. The housing fastens securely in a panel with thickness ranging from 0.09 to 1.00 inch. Multiple side by side stations can mount in a single panel opening. To install the station housing:

1. See Figure 3-2 for the station housing panel cutout and mounting dimensions. Prepare the panel opening accordingly.
2. Insert the housing through the panel opening until the front flange is in contact with the panel.
3. While holding the flange flush with the panel, rotate each of the 2 retaining clip screws counterclockwise to allow the clips to clear the thickness of the panel, then clockwise until the clips are snug against the back of the panel. Be careful not to over tighten the retaining clip screws.
4. Insure that the housing is secure.

**NOTE:** Do not install a SAC station in its housing until all of the appropriate cable connections are made. When replacing the NDCS03 station with the IISAC01 station, use the station housing that accompanies the SAC station. The SAC station does not fit into the DCS station housing. Additionally, use of the second analog input available with the SAC station requires replacement of the termination unit and termination cables. Both analog inputs are available on the NTCS04 Control I/O Termination Unit. Replace the cables with NKCS01 and NKCS02 cables.

---

### **Cable Lengths**

The station can be connected into a system with an NTCS04 termination unit and control station (KDS or KCS) cables. The NTCS04 termination unit routes two analog inputs to the SAC

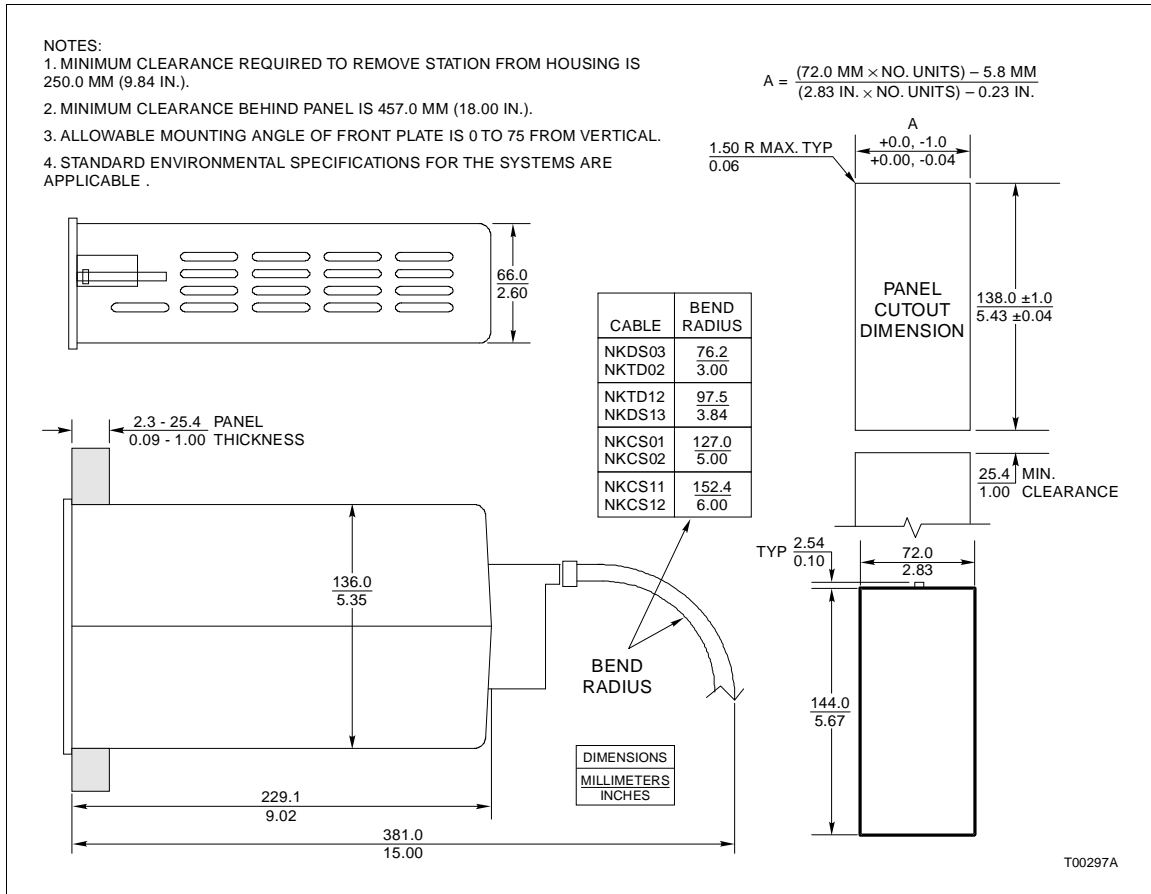

Figure 3-2. Station Housing Panel Cutout and Mounting Dimensions

station. Refer to Table 3-10 for termination unit and SAC station analog input designations. The KDS and KCS cables are functionally equivalent except for the number of analog inputs routed to the SAC station. The KDS cable only supports one analog input (AI1) while the KCS cable supports two analog inputs (AI1 and AI2). Refer to Tables 3-11, 3-12, and 3-13 for

Table 3-10. Termination Device and SAC Station Designator Relationship

| Termination Device               | Connector | Analog Input | Station Designator |
|----------------------------------|-----------|--------------|--------------------|
| NTCS04 Termination Unit          | P2        | AI3          | AI1                |
|                                  | P2        | AI1          | AI2                |
|                                  | P3        | AI4          | AI1                |
|                                  | P3        | AI2          | AI2                |
| NICS01/NIDS01 Termination Module | AO1       | AI3          | AI1                |
|                                  | AO2       | AI4          | AI1                |

cabling applications, connections and length restrictions. Refer to the appropriate termination unit manual for complete hardware descriptions.

**NOTES:**

1. The maximum cable length for the NKCS01, NKCS02 and NKTD02 cables also depends on the number of stations interconnected and the type of power system used. Tables 3-12 and 3-13 define the cable lengths depending on the power system and the number of SAC stations used.

2. Analog Inputs AI1 and AI2 are not available with the ICS termination module. AI1 may be displayed with the ICS/IDS pair. AI2 is not available with the ICS/IDS pair.

*Table 3-11. Cable Applications, Connections and Length Requirements*

| Cable             | Connections                |  |  |              | Maximum Length                |          |
|-------------------|----------------------------|--|--|--------------|-------------------------------|----------|
|                   | From                       |  | To   |              | Meters                        | Feet     |
|                   | Device                     | Connector  | Device                                       | Connector    |                               |          |
| NKCL01 and NKCL11 | NKTL01 cable               | N-type plug  | NKTL01                                       | N-type plug  | 3,000.0                       | 10,000.0 |
| NKCS01 and NKCS11 | TCS termination unit       | P2 or P3   | SAC station                                  | P1           | 137.16                        | 450.00   |
|                   | TRL termination unit       | P3   |  |              | Refer to Tables 3-12 and 3-13 |          |
| NKCS02 and NKCS12 | TCS termination unit       | P2 or P3   | First SAC station of interconnected stations | P1           | 137.16                        | 450.00   |
|                   | TRL termination unit       | P3   |  |              | Refer to Tables 3-12 and 3-13 |          |
| NKDS01 and NKDS11 | TCS termination unit       | P2 or P3   | SAC station                                  | P1           | 122.0                         | 400.0    |
|                   | TRL termination unit       | P3   |  |              | Refer to Tables 3-12 and 3-13 |          |
| NKDS02 and NKDS12 | TCS termination unit       | P2 or P3   | First SAC station of interconnected stations | P1           | 122.0                         | 400.0    |
|                   | TRL termination unit       | P3   |  |              | Refer to Tables 3-12 and 3-13 |          |
| NKDS03 and NKDS13 | Interconnected SAC station | NKDS02, NKDS12, NKCS02, NKCS12, NKDS01 or NKDS13 connector | Interconnected SAC station                   | P1           | 3.0                           | 10.0     |
| NKLM01 and NKLM11 | IMRIO02 module             | P3   | NTRL03 termination unit                      | P1           | 61.0                          | 200.0    |
| NKPL01 and NKPL11 | NTRL03 termination unit    | TB2, 5 and 6   | NTRL03 termination unit                      | TB2, 1 and 2 | 2,000.0                       | 6561.0   |

Table 3-11. Cable Applications, Connections and Length Requirements (continued)

| Cable                   | Connections            |               |                               |  | Maximum Length                |       |
|-------------------------|------------------------|---------------|-------------------------------|--|-------------------------------|-------|
|                         | From                   |               | To                            |  | Meters                        | Feet  |
|                         | Device                 | Connector     | Device                        | Connector                                    |                               |       |
| NKSE01 and NKSE02       | TCS termination unit   | P5            | TCS termination unit          | P4   | 61.0                          | 200.0 |
|                         | TCS termination unit   | P4            | TMP termination unit          | P4   |                               |       |
| NKTD01 and NKTD11       | IDS termination module | P1            | SAC station                   | KDS cable connector connected to SAC station | 0.61                          | 2.00  |
| NKTD02 and NKTD12       | ICS termination module | J2            | SAC station                   | P1   | 183.0                         | 600.0 |
|                         |                        |               |                               |  | Refer to Tables 3-12 and 3-13 |       |
| NKTM01                  | MFP module             | P3            | IMP or ICS termination unit   | P1   | 30.0                          | 100.0 |
| NKTU01 and NKTU11       | CIS module             | P3            | TCS termination unit          | P1   | 61.0                          | 200.0 |
|                         | Primary MFP module     | P3            | TMP termination unit          | P2   |                               |       |
|                         | Redundant MFP module   | P3            | TMP termination unit          | P1   |                               |       |
| NKTU02 and NKTU12       | MFP or CIS module      | P3            | IMP or ICS termination module | P1   | 61.0                          | 200.0 |
| R2041-1976 twisted pair | ICS termination module | TB21 and TB22 | IMP termination module        | P7   | 61.0                          | 200.0 |

Table 3-12. INFI 90 Power System Maximum Cable Length

| Number of Stations | Cable                                    | Maximum Length |      |
|--------------------|--|----------------|------|
|                    |  | Meters         | Feet |
| 1                  | NKCS01, NKCS02, NKDS01, NKDS02 or NKTD02 | 137            | 450  |
| 2                  | NKCS02, NKDS02 or NKTD02                 | 60             | 200  |
| 3                  | NKCS02, NKDS02 or NKTD02                 | 45             | 150  |
| 4                  | NKCS02, NKDS02 or NKTD02                 | 30             | 100  |

Table 3-13. Network 90 Power System Maximum Cable Length

| Number of Stations | Cable                                    | Maximum Length |      |
|--------------------|--|----------------|------|
|                    |  | Meters         | Feet |
| 1                  | NKCS01, NKCS02, NKDS01, NKDS02 or NKTD02 | 106            | 350  |
| 2                  | NKCS02, NKDS02 or NKTD02                 | 45             | 150  |
| 3                  | NKCS02, NKDS02 or NKTD02                 | 30             | 100  |
| 4                  | NKCS02, NKDS02 or NKTD02                 | 22             | 75   |

The ICS termination module with the NKTD02 cable supplies only the power and the serial link to the SAC station. The SAC station cannot be a bypass station. The NKDS03 cable interconnects up to three additional nonbypass stations. The NICS01/NIDS01 termination module pair is required to allow a station to have bypass capability. The NICS01 termination module is connected to the NIDS01 termination module with a ribbon cable (part number 6634408A2).

The NIDS01 termination module uses the NKTD01 cable which can support two four-station interconnection links. Only the first station in the interconnection has bypass capability. The other three are nonbypass stations.

---

**Termination Unit Cable and Wiring Installation (Single or Double Station)**

To install the cables and wires to the termination unit handling a single or double station setup:

1. Connect the wiring from the electric drive, analog output and analog inputs to the termination unit. Refer to [Appendix A](#) for terminal assignments.
2. Connect one end of the NKCS01 or NKDS01 (only 1 analog input with NKDS01) cable to P2 or P3 on the termination unit. To install a double station, install a cable in P2 and P3. Figure 3-3 shows a diagram of a double station installation.

**NOTE:** The station connected to P2 of the TCS termination unit bypasses analog output 1. The station connected to P3 of the TCS termination unit bypasses analog output 2.

---

**Termination Unit Cable Installation (Interconnected Stations)**

To install the cables to the termination unit handling interconnected stations:

1. Connect the KCS cable to P2 or P3 on the termination unit.

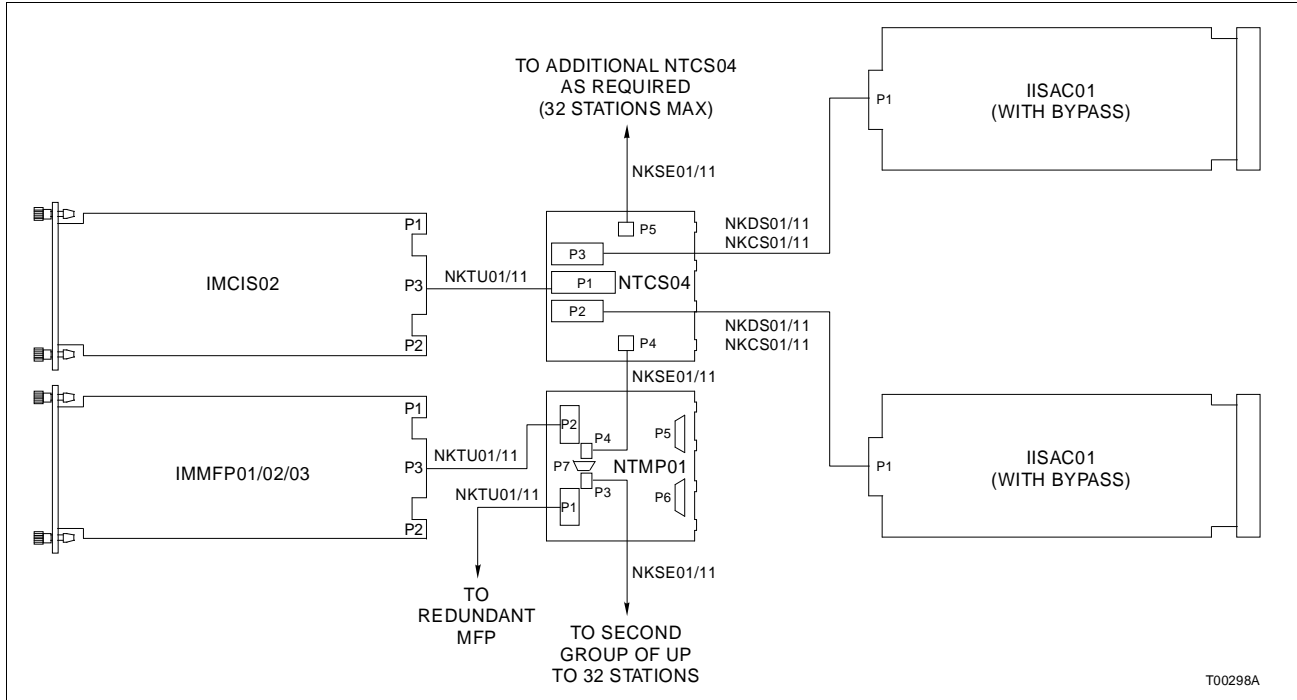

Figure 3-3. Cable Connections for Two Analog Control Stations on One TCS Termination Unit

2. Connect the successive stations (maximum of 8, 4 from P2, 4 from P3) to the first station using a KCS (only 1 analog input with KDS), NKDS02 or NKDS12 cable. There is an additional connector on the KCS or KDS that connects to the NKDS03 and NKDS13 cable. Figure 3-4 shows a diagram of an interconnected installation.

**NOTE:** Only the first interconnected SAC station can bypass an analog output. The first interconnected SAC station connected to P2 of the TCS termination unit bypasses analog output number 1. The first interconnected SAC station connected to P3 of the TCS termination unit bypasses analog output number 2.

**Cable Connections for the NTRL03 Termination Unit**

Figure 3-5 shows the cable connections for the NTRL03 termination unit. For more information refer to the **NTRL02 and NTRL03 Fiber Optic Remote Link and Electrical Remote Link Termination Units** product instruction.

**Cable Connections for the NIRL03 Termination Module**

Figure 3-6 shows the cable connections for the NIRL03 termination module. For more information refer to the **NIRL03 Remote Link Termination Module** product instruction.

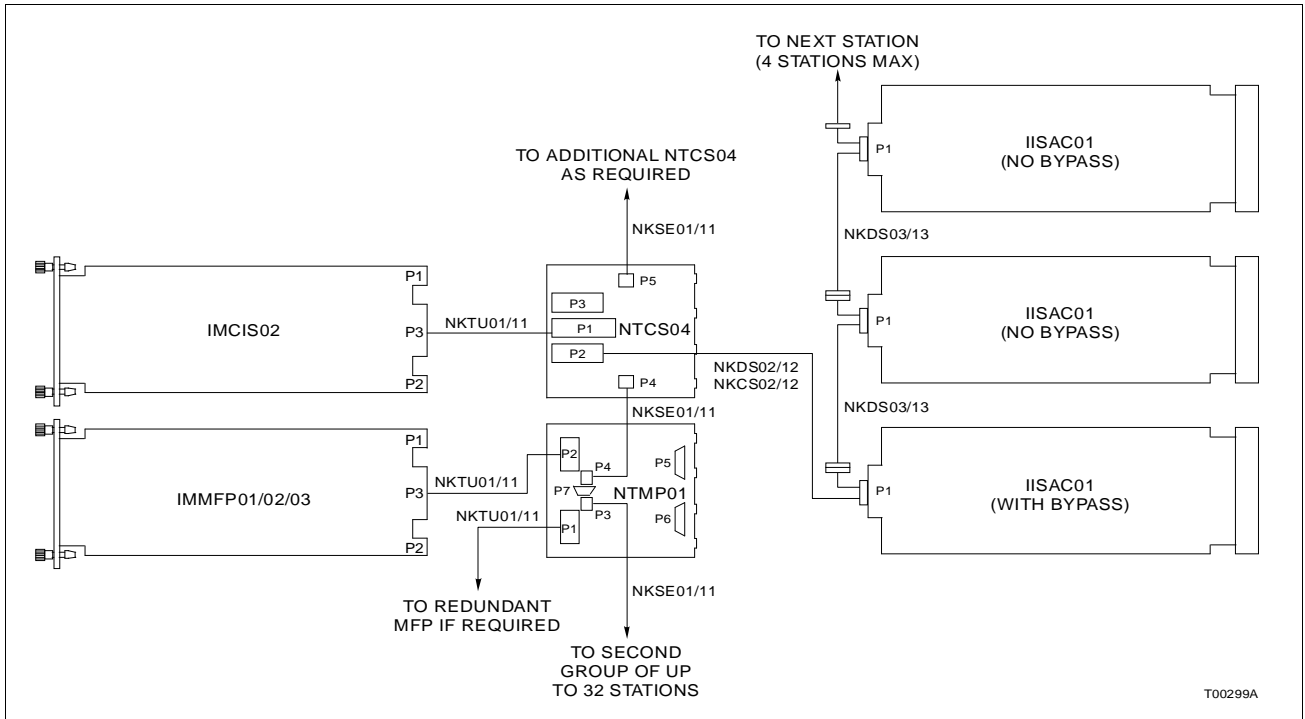

Figure 3-4. Cable Connections for TCS Termination Unit with Multiple Interconnected SAC Stations

### Termination Module Cable Installation (without Bypass)

To install the termination module without bypass:

1. Partially remove the termination module from the termination mounting unit (TMU) leaving the terminals next to the faceplate exposed.
2. Connect one end of the KDS cable to J2 of the ICS termination module. Connect the other end of the cable to the rear of the station housing for the analog control station.
3. Connect twisted pair serial link wiring between NIMP01 and NICS01 modules. Take care not to cross A and B serial channels.
4. Push the termination module into the TMU unit until it seats in the KTM or KTU cable connector in the TMU backplane (cable from termination module to the module).
5. The ICS termination module can terminate up to 4 SAC stations without bypass. Figure 3-7 shows a cable diagram of one station terminated on the ICS termination module.

**NOTE:** No analog inputs are available for display purposes in the SAC station when using an NICS01 termination module.

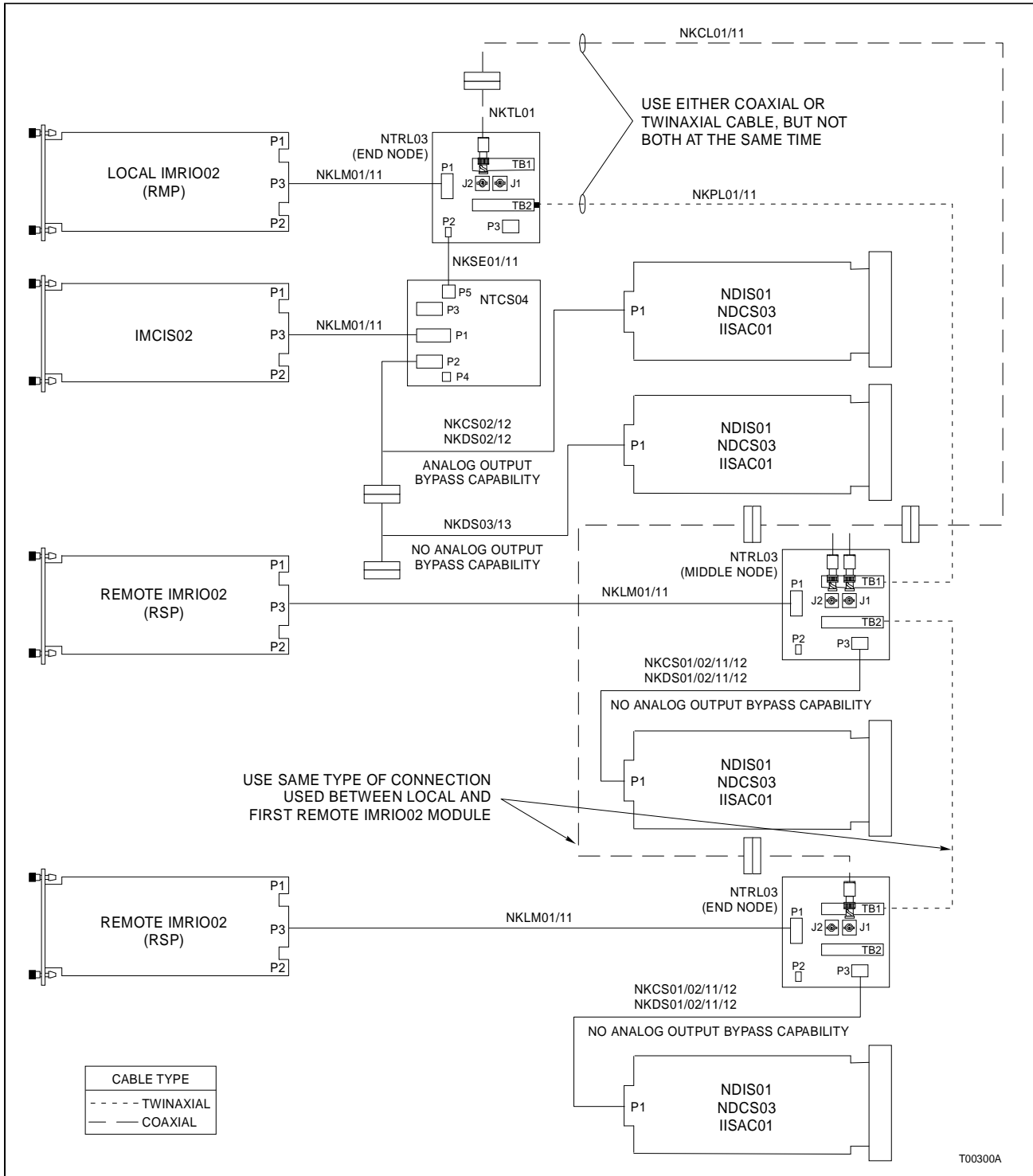

Figure 3-5. Cable Connections for the NTRL03 Termination Unit



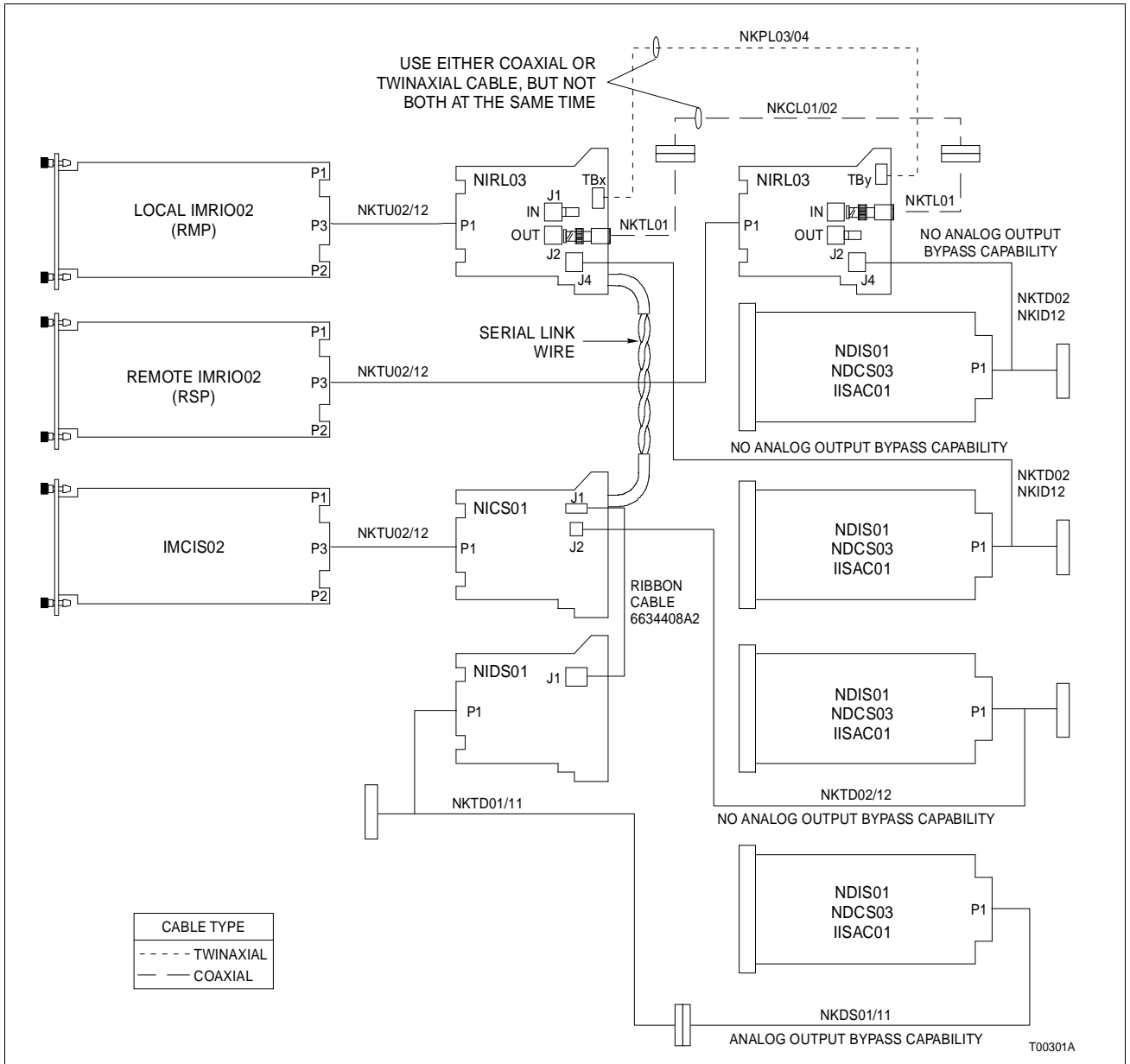

Figure 3-6. Cable Connections for the NIRLO3 Termination Module

**Termination Module Cable Installation (with Bypass)**

To install the termination module with bypass:

1. Partially remove the ICS and IDS termination modules from the termination mounting unit (TMU) leaving the terminals next to the faceplate exposed.

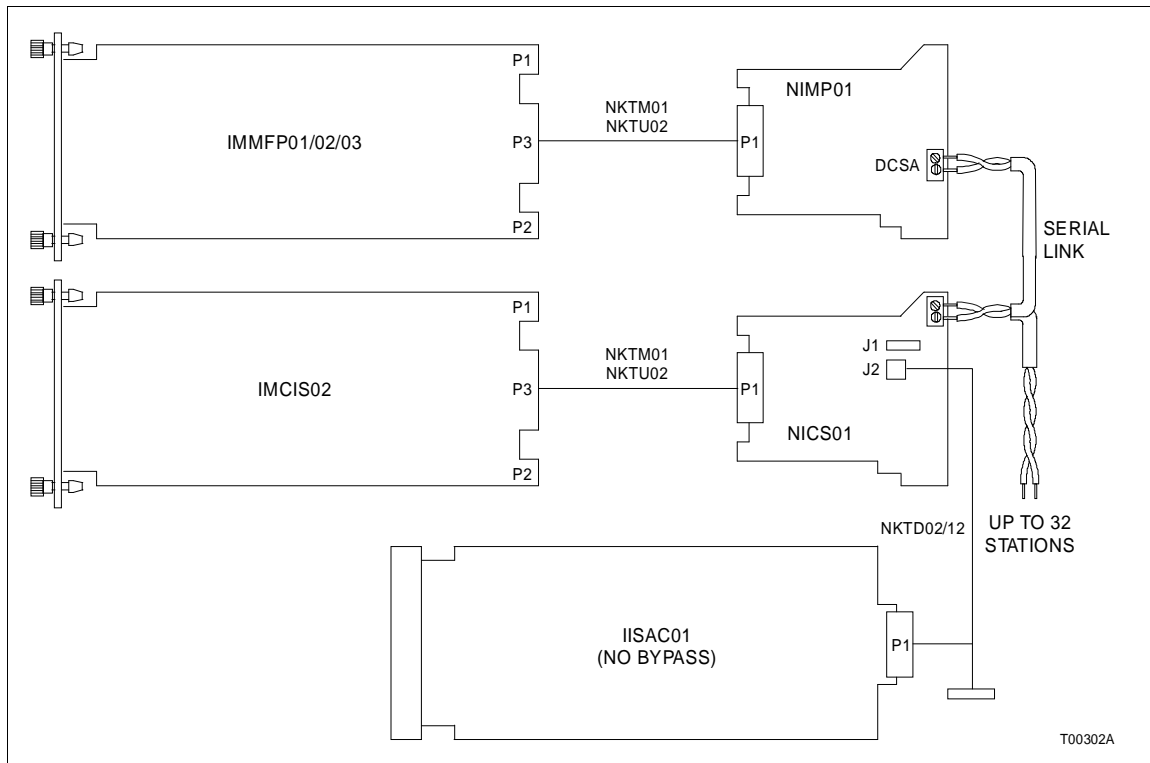

Figure 3-7. Cable Connections for the ICS Termination Module with One Station, No Bypass

2. Connect the end of the NKTD01 with 1 connector to the slot on the TMU backplane that is assigned to the IDS termination module.
3. Connect J1 on the ICS termination module to J1 on the IDS termination module using ribbon cable 6634408A2.
4. Connect twisted pair serial link wiring between NIMP01 and NICS01 modules. Take care not to cross A and B serial channels.
5. Push the termination module into the TMU unit until it seats in the NKTM01 and NKTM11, or NKTU02 cable connector in the TMU backplane (cable from termination module to the module).
6. Figure 3-8 shows a termination module and single station with bypass and interconnection configuration with 1 bypass and 2 nonbypass stations. A maximum of 4 stations can be interconnected together.
  - a. The NKTD01 cable connected to the IDS termination module has 2 connectors to support two 4-station interconnection configurations.

b. Connecting an NKDS01 cable to the NKTD01 connector provides a single station with bypass.

c. Connecting an NKDS02 cable to the NKTD01 connector provides the ability to interconnect up to 4 stations. Only the station connected to the NKDS02 cable has bypass capability. The NKDS03 cable connects the remaining non-bypass stations together and to the NKDS02 cable.

**NOTE:** Only 1 analog input is available to the bypass station when using the NICS01/NIDS01 termination module pair.

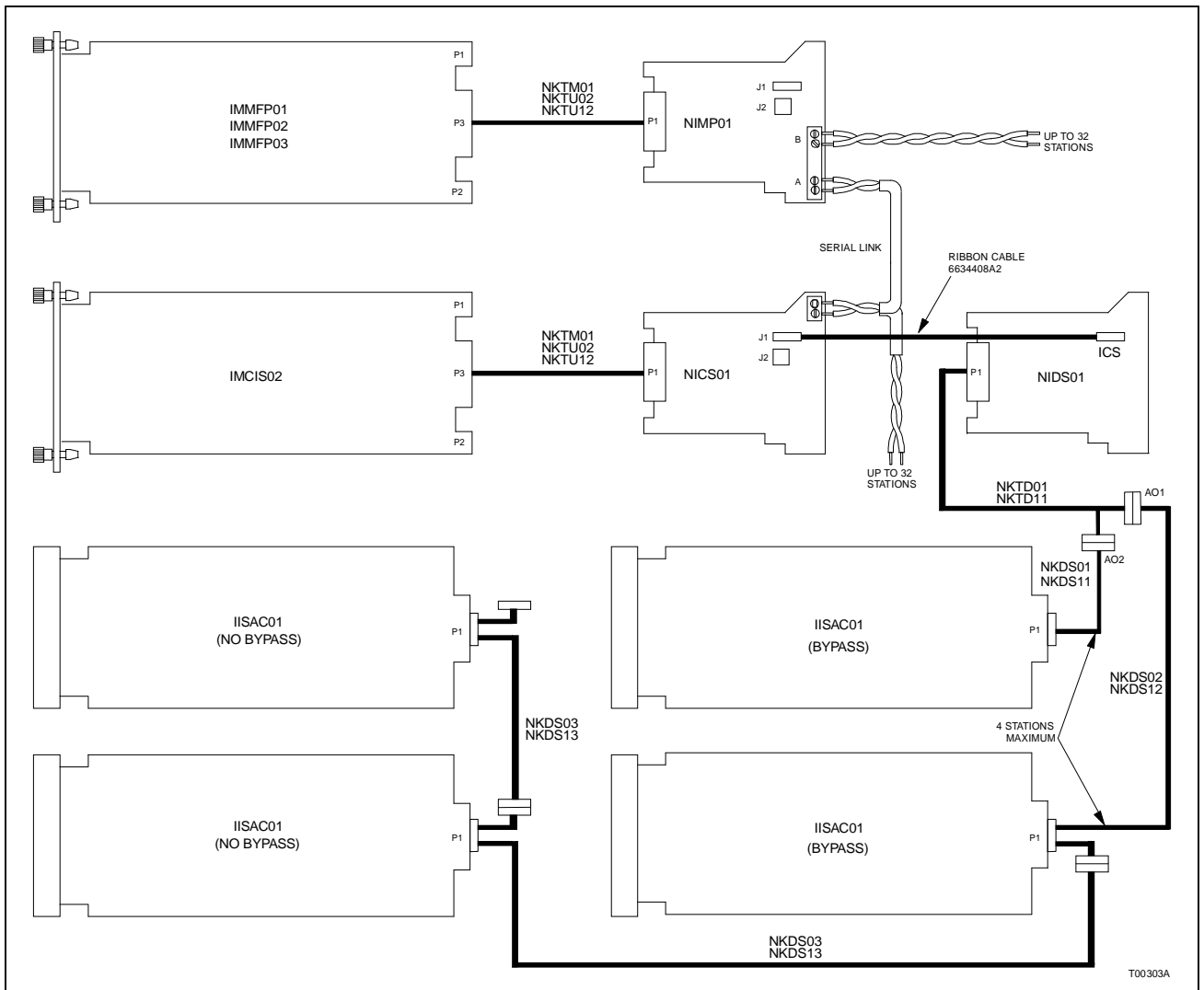

Figure 3-8. Cable Connections for the ICS and IDS Modules with Interconnected Stations and Bypass

---

### **Connecting Termination Cables to Station Housing**

The termination cable edge connector snaps securely into place in the back of the station housing. Partially remove the station from the housing before fastening the cable to the housing. Viewing the station housing from the rear, the cable fastens to the right side of the station housing.

If the cable connector does not fit properly in the housing, do not force the connector into position. The connector slots in the housing contain small notches that allow the connector to be inserted one way. Be aware of these notches when inserting the connector in the station housing.

---

### **INSERTING AND REMOVING THE ANALOG CONTROL STATION**

Insert the analog control station in its housing only after the proper connections are made. Be sure to observe special handling procedures when handling electronic circuitry. Before inserting the station in its housing verify that:

1. The termination cable is properly connected to the termination unit and to the correct slot of the station housing.
2. All station operating and display options have been selected and recorded.

---

#### **Inserting the Analog Control Station**

|                  |   |
|------------------|---|
| <b>CAUTION</b>   | <b>Remove a station from its housing before installing or removing the station cable to the station housing. Failure to observe these precautions could result in equipment damage.</b> |
| <b>ATTENTION</b> | <b>Retirer le poste de son boîtier avant d'installer ou de retirer le câble du poste du boîtier. Un manquement à cette précaution pourrait causer des dommages à l'équipement.</b>      |

To insert the SAC station in its housing:

1. Facing the front of the station housing, align the upper and lower edges of the circuit board with the upper and lower guide rails on the left hand side of the station housing.
2. Open the legend door. Insure the captive screw is loose.
3. Push on the left edge of the SAC station faceplate, sliding the circuit board into the housing until P1 on the SAC station circuit board seats in the cable connector at the rear of the housing.

4. Use a straight blade screwdriver to turn the captive screw behind the legend door, locking the station in place.

---

### ***Removing the Analog Control Station***

To remove the SAC station from its housing:

**NOTE:** Extended grounds allow disconnection of the station from the front of the station housing without damage. The extended grounds are the last contact (with power) the station sees when removing the station from its housing (i.e., the station loses power before the ground is disconnected).

1. Open the legend door.
2. Use a straight blade screwdriver to turn the captive screw to unlock the station from the housing.
3. Grasp the station faceplate from the top and bottom at the left edge and pull the station to disconnect it from its cable connection and remove it from the housing.

---

### ***FUNCTION CODE CONFIGURATION***

Configure the module so that the analog control station will operate within the system control strategy. The station is interfaced to a control strategy by the station function code 80. Function codes reside in the module. To configure the module you need:

1. The instruction for the operator interface/configuration device in your system (i.e., OIS, CTM, EWS).
2. The ***Function Code Application Manual***.
3. The instruction for the module in your system.

**NOTE:** The associated analog output is specified by S28 of function code 80. The associated analog output must reference one of the analog outputs (N+4 or N+5) of function code 79.

# SECTION 4 - OPERATING PROCEDURES

## INTRODUCTION

This section covers IISAC01 Analog Control Station (SAC) start-up and operation. It identifies station faceplate displays, special alphanumeric characters, error codes and explains how they function in relation to the membrane pushbuttons.

## FACEPLATE OPERATION

The operator monitors and initiates actions through the station faceplate. Figure 4-1 shows the SAC station faceplate with membrane pushbuttons, manual override switch, annunciators, bar graphs and alphanumeric display.

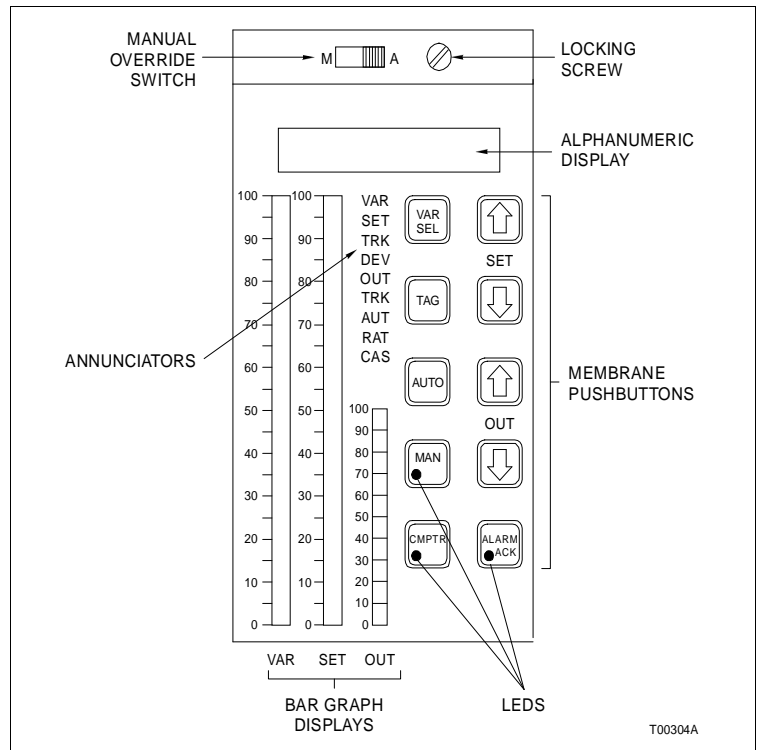

Figure 4-1. SAC Faceplate

### Alphanumeric Display

The alphanumeric display is an eight-digit display. Each digit displays the full range of decimal numbers (zero through nine),

letters (A through Z), and two special characters (refer to Table 4-1).

**NOTE:** The alphanumeric display is capable of displaying a range of values between the values of -9999 and +9999. Values not within these limits will be displayed as either -9999 or +9999 on the alphanumeric display.

The display uses a floating decimal point and can output a value in the range of a four-digit number (no decimals) to a one-digit number (two decimal places) in engineering units or percentage. Information that appears on the display includes:

1. When the station is in normal operation, the following variables can appear on the alphanumeric display.
  - a. Numeric value of the process variable (PV) in engineering units.
  - b. Numeric value of the set point (SP) in engineering units.
  - c. Numeric value of the control output (CO) in percent of output.
  
2. When the station is in either stand-alone or bypass/manual override operation, the demand output (DO) appears in percent on the alphanumeric display. The demand output is not applicable when the electric drive mode option is enabled.
  
3. When an error and alarm condition exists, refer to Table 4-2 for error and alarm codes and their meanings. For more information refer to Section 5.

Table 4-1. Special Characters on the Alphanumeric Display



| Character   | Meaning  |
|---|--|
|  | Three horizontal lines in the leftmost digit of the alphanumeric display indicate that the station is in the stand-alone mode of operation.  |
|  | A square appears in the leftmost digit when the station is in the bypass mode or manual override of operation.   |
| E   | The letter E appears in the second place (digit) from the left when the station is in bypass/manual override or stand-alone and the electric drive option is enabled.                  |
| E01   | The letter E followed by a decimal number (E01-E20) in the 3 rightmost digits identifies an alarm condition or a module error. Table 4-2 lists the SAC station error codes and alarms. |

Table 4-2. Analog Control Station Error Codes and Alarms

| Code | Meaning  |
|------|--|
| E01  | <b>Error - Module Communication Failure</b> - Occurs when there is a loss of communication between the station and the module. The station enters the stand-alone mode or goes directly to bypass operation if the auto bypass option is selected.                                   |
| E02  | <b>Error - 5 kbaud Communication Rate Address</b> - Occurs when the 5-kbaud serial communication rate is selected and the station has an invalid address. Valid addresses for the 5-kbaud mode are 0 through 7. A limit of 8 stations can be placed on a 5-kbaud communication link. |

Table 4-2. Analog Control Station Error Codes and Alarms (continued)

| Code         | Meaning   |
|--------------|---|
| E03          | <b>Alarm - Analog Input 2 (AI2) Low</b> - Occurs when the second analog input signal falls below 0.75 V (less than -5%). This error condition does not disrupt station operation. It warns the operator that the analog input signal is out of the specified operating range (1 to 5 VDC).  |
| E04          | <b>Alarm - Analog Input 2 (AI2) High</b> - Occurs when the second analog input signal rises above 5.25 V (greater than 105%). This error condition does not disrupt station operation. It warns the operator that the analog input signal is out of the specified operating range (1 to 5 VDC).   |
| E05          | <b>Alarm - Analog Input 1 (AI1) Low</b> - Occurs under the same conditions as E03 but applies to the analog input 1.  |
| E06          | <b>Alarm - Analog Input 1 (AI1) High</b> - Occurs under the same conditions as E04 but applies to the analog input 1.   |
| E07          | <b>Alarm - Analog Output Low</b> - Occurs when the analog output signal falls below 3 mA (less than -5%). This error condition does not disrupt station operation. It warns the operator that the analog output signal is out of the specified operating range (4 to 20 mA).  |
| E08          | <b>Alarm - Analog Output High</b> - Occurs when the analog output signal rises above 21 mA (greater than 105%). This error condition does not disrupt station operation. It warns the operator that the analog output signal is out of the specified operating range (4 to 20 mA).  |
| E09          | Not used.   |
| E10          | <b>Alarm - Low Alarm from the MFC/MFP</b> - External low alarm defined by the user. The block address for this alarm is in specification S25 of function code 80. This error condition does not disrupt station operation.  |
| E11          | <b>Alarm - High Alarm from the MFC/MFP</b> - External high alarm defined by the user. The block address for this alarm is in specification S24 of function code 80. This error condition does not disrupt station operation.  |
| E12          | <b>Alarm - Process Variable (PV) Low</b> - Occurs when the process variable falls below a value set by the user in S8 of function code 80. This condition does not disrupt station operation. It warns the operator that the process variable is below a predetermined limit.   |
| E13          | <b>Alarm - Process Variable (PV) High</b> - Occurs when the process variable rises above a value set by the user in S7 of function code 80. This condition does not disrupt station operation. It warns the operator that the process variable is above a predetermined limit.  |
| E14 -<br>E15 | Not used.   |
| E16          | <p><b>Error - Membrane Pushbutton Fault</b> - Occurs when the software detects a fault in the operation of the frontplate pushbuttons. E16 can also be generated by an operator pressing more than one pushbutton at a time. The pushbuttons detected as faulty will not be processed by the software as valid pushbutton entries.</p> <p>The E16 error remains in the alarm list to indicate that a keypad fault occurred. If the fault is caused by pressing multiple keys at the same time, normal keypad operation resumes when the membrane pushbutton fault alarm is cleared. Clear the E16 error by cycling through the alarm list using the ALARM ACK pushbutton. If the membrane pushbutton fault still exists after cycling through the alarm list, then the E16 error will not be cleared.</p> |
| E17          | <b>Error - Station Fault</b> - Occurs when a hardware fault in the station microprocessor or computer operating properly (COP) watchdog time-out occurs, resulting in a complete station failure.   |
| E18          | <b>Error - Configuration Register Failure</b> - Warns the operator improper station microprocessor configuration or it cannot be configured. Configuration error failure will cause the station to halt operation.  |
| E19          | <b>Error - Electric Drive Display Option</b> - Occurs when either the stand-alone or bypass/manual override display options are incorrectly set for station operation with the electric drive option enabled.   |
| E20          | <b>Error - M/A Switch Position</b> - Occurs when the M/A switch is in the <b>M</b> position on power up. Placing the switch in the <b>A</b> position allows the SAC station to enter stand-alone operation until the MFP module establishes communication with the station.   |



---

## Annunciators

There are nine annunciators on the station faceplate. They are located above the control output (CO) bar graph. Table 4-3 lists the function of the annunciators.

Table 4-3. Annunciators

| Annunciator | Indicates   |
|-------------|---|
| AUT         | The station is operating as an automatic basic station.                                 |
| CAS         | The station is operating as a cascade station.  |
| DEV         | Not used at this time.  |
| OUT         | The value currently displayed on the alphanumeric display is the control output (CO).   |
| OUT TRK     | Control output tracking is active.  |
| RAT         | The station is operating as a ratio station.  |
| SET         | The value currently displayed on the alphanumeric display is the set point (SP).        |
| SPT TRK     | Set point tracking is active.   |
| VAR         | The value currently displayed on the alphanumeric display is the process variable (PV). |

---

## Bar Graph Displays

There are three bar graph displays (see Figure 4-1). They display the process variable, control output, demand output, analog inputs one and two, or set point depending on the display options selected for each mode of operation.

Tables 3-5, 3-6, and 3-7 lists all combinations of display options for each mode of operation. Refer to the bar graph option settings recorded in the user setting section of Tables 3-5, 3-6, and 3-7 when necessary.

---

## Membrane Pushbuttons











There are ten membrane pushbuttons on the SAC station faceplate. The membrane pushbuttons are momentary, single position contacts. Table 4-4 lists the membrane pushbuttons and their function. See Figure 2-2 for a flow diagram of the SAC station operation.

---

## Manual Override Switch

The manual override switch forces the control system into open loop control. The operator has direct control of the process from the **OUT** pushbuttons. The process can be monitored by the user definable display options. Placing the switch in the manual (**M**) position overrides all station operating modes and locks the station in manual override. Return the switch to the auto (**A**) position to unlock manual override.

Table 4-4. Membrane Pushbutton Operation

| Pushbutton   | Action   |
|--|--|
|   | <p>Selects the variable that appears on the alphanumeric display. It cycles through the process variable, set point and control output. The PV and SP are displayed as decimal values in engineering units, the CO is displayed as a decimal value in percent. The annunciators to the left of this pushbutton indicate which variable appears on the alphanumeric display.</p>  |
|  <p>SET</p>      | <p>Raises or lowers the set point when the station is operating as an automatic or manual basic station. Raises or lowers the ratio index of the controlled variable when operating as a ratio station. Holding the pushbutton closed increases the rate the set point or ratio index changes. These pushbuttons have no effect when the station is in the automatic cascade, bypass/manual override, stand-alone mode of operation, set point tracking or computer control.</p>   |
|   | <p>Reserved for future use.</p>  |
|   | <p>Transfers the operating mode from manual basic to automatic basic. If the station is in the auto mode and configured as a cascade or ratio station, pressing this pushbutton a second time toggles the station between auto basic and auto cascade/ratio.</p>   |
|   | <p>Transfers operation from automatic (basic, cascade or ratio) to manual basic. The LED inside the pushbutton is on when the station is in the manual mode of operation.</p>  |
|  <p>OUT</p>  | <p>Raises or lowers the control output when the station is in the manual mode of operation. Raises or lowers the demand output when the station is in bypass operation or manual override. It also raises or lowers the targeted demand output from the station to match the control output of the CIS module when the station is in stand-alone operation. Holding the pushbutton closed increases the rate the CO or DO changes.</p> <p><b>or</b></p> <p>Energizes the raise or lower relay for the electric drive with the electric drive option enabled and the station is in bypass or stand-alone operation.</p> |
|   | <p>Toggles computer mode on and off. The LED inside the pushbutton is on when the station is in computer mode. Computer mode prevents the raising and lowering of both the set point and control output of the SAC station via the pushbuttons. This allows for the exclusive access of the control variables by a remote computer.</p>  |
|  <p>T00315A</p>   | <p>Acknowledges process variable alarms and cycles through the alarm values on the alphanumeric display. The LED within the pushbutton flashes when alarm conditions are present. The LED stops flashing with all alarm conditions acknowledged but, remains on while alarm conditions continue.</p>   |

The manual override switch is behind the legend door at the top of the analog control station faceplate (see Figure 4-1).

**NOTE:** Toggling the M/A switch to reset the CIS/MFP/SAC combination when there is a faulty CIS module, bad cabling or field termination causes a potential loss of control. Control is suspended for 500 milliseconds from the time the M/A switch is toggled until the station returns to bypass.

In normal operation, with the load removed from the analog output and then applied, the CIS/SAC/MFP combination becomes locked into bypass mode until one of the three modules is reset. The removal of the load can be caused by a bad CIS cable, field wiring, termination device failure or a field device failure. On stations that have firmware revision B.3 or higher, the operator can remove the control loop from the locked bypass condition using the M/A switch. Do this by toggling the M/A switch from **A** to **M**, and then back to **A**. Only use this procedure if the cause of the SAC station entering bypass is an open load and the load is reconnected before using the M/A switch. Under these conditions, toggling the M/A switch removes the control loop from bypass with no loss of control (bumpless transfer).

If the cause of bypass is a faulty CIS module or related cabling or termination, toggling the M/A switch causes loss of control for 500 milliseconds before the SAC station returns to bypass. During the 500 milliseconds the control output will be zero milliamps. Refer to the corrective action for error codes E07 and E08 in Table 5-1 for more information.

---

## STATION START-UP AND OPERATION

Station start-up is automatic when the station is inserted in the station housing and receives power. The station does a sequence test on the faceplate displays before it begins normal operation. The steps of the faceplate sequence test are:

1. The bar graphs ramp from 0 to 100%.
2. Each annunciator turns on in sequence from top to bottom.
3. Each LED lights in this order:  
  
MAN.  
ALARM ACK.  
CMPTR.
4. The alphanumeric display runs through a walking segment test from left to right.

This test does not halt on a display failure. The operator must observe the faceplate during the sequence test to determine if

the faceplate display is operating properly. Upon completion of the faceplate display test the station enters the stand-alone mode.

---

### **Stand-Alone**

After successful initialization, the station enters the stand-alone mode while the module attempts to establish communication with the station. From the stand-alone mode the station can:

- Enter normal operation after the module establishes communication.
- Remain in stand-alone until a communication link to the module is established.
- Be forced into manual override through operator action.
- Be forced into auto bypass operation by the module after it establishes communication.

When in the stand-alone mode and the electric drive option is enabled, the **OUT** pushbuttons cause the raise/lower relay contact output to close. Thus, the operator has immediate control of the process.

When the station is in stand-alone mode, the operator can place the station in manual override (if the station is a bypass station, JP1 has pins one and two jumpered and the manual override switch is enabled). To place the station in manual override from the stand-alone mode:

1. Use the control output raise/lower pushbutton (refer to Table 4-4) to target the value of the demand output from the station. Target the station demand output to the value of the control output from the control I/O module. Targeting the DO value to the CO value gives a smooth transfer of control. To target the demand output:
  - a. A stand-alone display option allows the VAR SEL switch to toggle the AI1 (if AI1 is CO signal from the CIS module) and DO values on the OUT bar graph display. Compare the 2 values. Toggle AI1 and DO and adjust the DO until it matches the AI1 value.
  - b. If AI1 is not monitoring the CO signal from the CIS module, measure the value (using a voltmeter) of the CO at the termination unit terminal blocks. Calculate what percentage of full value is at the termination unit CO terminals and adjust the DO to match that value.

2. When the CO and DO are approximately the same value, place the manual override switch in the manual (**M**) position (Figure 4-1 shows the location of the manual override switch). Once the station transfers to manual override, the station exits the stand-alone mode.

3. The DO from the station is now the active control signal to the process. Raise or lower the DO through the control output raise/lower pushbutton on the station faceplate. The station is locked into manual override.

To exit manual override, place the manual override switch in the auto (**A**) position. The station transfers to bypass operational mode until it establishes communication with the module. When the module establishes communication with the station, it forces the station to remain in bypass mode or enter normal operation.

---

### **Normal Operation**

The operator has direct input into the process when the station is in manual basic, auto basic, ratio or bypass/manual override mode of operation. In manual basic operation, the operator sets the control output from the station. The module reads the value of the control output the operator sets with the **OUT** raise/lower pushbutton and sends that value to the CIS module. The adjustment of set point has no effect on the process until it is in auto mode.

**NOTE:** Enabling control output or set point tracking via function code 80 disables the related set of pushbuttons.

In auto basic operation, the operator sets the set point from the station with the **SET** raise/lower pushbutton. The module reads the value of set point from the station and adjusts the control output of the CIS module according to the control algorithm. When the station is operating as a ratio station, the operator can set the ratio index from the station with the **SET** raise/lower pushbutton. The set point bar graph displays the value of the set point that the operator enters via the **SET** pushbuttons. The **SET** pushbuttons have no effect when the station is operating as a cascade station (the control algorithm internally generates the set point). The station displays the value of the set point that the module generates and sends to the station while it is in cascade.

---

### **Changing Control Strategies in Normal Operation**

The operator can select any control strategy (basic, cascade or ratio) from the **AUTO** pushbutton. Pressing the **AUTO** pushbutton transfers the station between available control strategies. For example, the station is typically defined to enter normal mode of operation in basic/manual. When the **AUTO**

pushbutton is pressed, the station transfers to basic/automatic. Additional depressions of the **AUTO** pushbutton causes the station to toggle between the other available control strategies. To return to basic/manual, press the **MAN** pushbutton. Refer to Table 4-4 for a description of pushbutton operation in relation to function code 80.

---

### ***Bypass/Manual Override Operation***

When the station enters bypass/manual override operation, the demand output from the station is the value of the control output contained in the latest update message from the module. Table 4-1 explains how the alphanumeric display notifies the operator that the station is in bypass/manual override operation. The operator can adjust the demand output using the **OUT** raise/lower pushbutton. If the station is in the bypass operational mode because of a communication failure, it will return to normal operation when module to station communication is established. If a failed analog output forces the station into bypass, the station will stay in bypass until the problem is resolved.

If the station is in manual override mode, placing the M/A switch to the **A** position transfers the station to bypass mode. If the electric drive option is enabled, the **OUT** raise/lower pushbutton energizes the electric drive raise/lower relay contact outputs.

---

### ***Acknowledging Alarms***

The LED within the alarm acknowledge pushbutton blinks when an alarm condition exists. Table 4-4 explains how to acknowledge and review alarms. Refer to Table 4-2 for a list of error codes and their meaning. Refer to Table 5-1 for corrective action to take for station error codes. Refer to the plant operating procedure or contact your system engineer or technician for steps to take for an alarm condition.

---

# SECTION 5 - TROUBLESHOOTING

---

## INTRODUCTION

This section explains how to troubleshoot general station and system failures. It includes troubleshooting flowcharts and tables containing corrective action.

---

## HOW TO USE THIS SECTION

You can effectively troubleshoot a failure by using the flowcharts to isolate the failure. After locating the failure, refer to the troubleshooting tables or other related documents for more information about the failure and corrective action.

**NOTE:** Troubleshooting involves physical contact with the system, including the handling of circuit boards with electrostatic devices. To avoid creating additional problems while troubleshooting, always use Bailey Controls field static kit (part number 1948385A1) when working with the SAC station. The kit connects a technician and the static dissipative work surface to the same ground point to prevent damage to the station circuit by electrostatic discharge.

---

## ERROR CODES

**NOTE:** Always secure control of the loop through another source before disconnecting the station, if a failure occurs while the station is in bypass operation or manual override. Failure to secure control of the loop under these conditions can result in loss of process control and damage to plant equipment.

Table 5-1 lists the error code conditions that interrupt station operation, the cause of those conditions, and corrective action. Refer to Table 4-2 for a complete list of error codes and alarms, and their meaning. Table 4-4 explains how to acknowledge alarms and view error codes on the alphanumeric display. Figures 5-1 through 5-8 are troubleshooting flowcharts for the error codes listed in Table 5-1.

---

## GENERAL FAILURES

Some station failures are recognizable through the misoperation of the station faceplate. Table 5-2 lists faceplate conditions, cause, and corrective action for these failures. Figure 5-8 is a troubleshooting flowchart for general operational station failures.

Table 5-1. Corrective Action for SAC Error Codes

| Condition  | Problem                   | Cause  | Corrective Action  |
|--|---------------------------|--|--|
| E01  | Loss of communication.    | Poor or open cable connection.   | <p>Check cable connections.</p> <p>For termination units:</p> <ol style="list-style-type: none"> <li>1. Verify that the station cable connects P1 on the station to P2 or P3 on the TCS termination unit.</li> <li>2. Verify that the module termination cable connects P3 on the controller or processor module to P1 on the TCS termination unit.</li> </ol> <p>For termination modules:</p> <ol style="list-style-type: none"> <li>1. Verify that station cable is correctly connected from P1 to either the J2 socket of the ICS termination module or to the AO1 or AO2 connector of the KTD cable that connects to the P1 connector of the IDS termination module.</li> <li>2. If the ICS/IDS termination module pair is used, insure that a ribbon cable is connected between the J1 socket on each termination module.</li> <li>3. Verify that the module cable connects P3 to P1 connector on the ICS termination module</li> </ol> |
|  |                           | Bad module.  | <p>Check the status of the module.</p> <p>Refer to the module product instruction for information about module status LEDs and corrective action.</p>  |
|  |                           | Bad function code configuration.   | Check function code 80 configuration within the module. Insure baud rate of station and module match.  |
| E02  | Station address error.    | Invalid address selected for a station operating with a 5-kbaud serial link. | Remove the SAC station that shows the error code and check its address (S1). The address must be 0 through 7.  |
| E03, E04, E05 and E06                              | Analog input low or high. | Bad field device or wiring.  | Repair field device or wiring.   |
|  |                           | Bad termination device or cable.   | Remove the SAC station with the error and replace it with a known good station.  |
|  |                           | Bad station.   | Remove the SAC station with the error and replace it with a known good station.  |
| E07 with station in normal mode                    | Analog output low.        | Fault in SAC station circuitry.  | Remove the SAC station with the E07 error and replace it with a known good station.  |
| E07 with SAC station in forced bypass <sup>1</sup> | Analog output low.        | Load removed from AO, bad CIS module, bad cable connection to termination.   | <p>Restore control of the process.</p> <ol style="list-style-type: none"> <li>1. Check the load to see if it is open from the control loop. If it is open, the process is not being controlled. Reconnect the AO to the load.</li> </ol>   |



*Table 5-1. Corrective Action for SAC Error Codes (continued)*

| <b>Condition</b>  | <b>Problem</b>  | <b>Cause</b>   | <b>Corrective Action</b>   |
|---|---|--|--|
| E07 with SAC station in forced bypass <sup>1</sup><br>(continued) | Analog output low.  | Load removed from AO, bad CIS module, bad cable connection to termination. | <ol style="list-style-type: none"> <li>2. If the load was open and restored, remove the loop from bypass by placing the M/A switch in the <b>M</b> position, then to the <b>A</b> position.</li> <li>3. If the load on the AO checks good, check the CIS module. Replace it with a good CIS module to restore operation.</li> <li>4. If the load on the AO checks good, check the cabling to the CIS module and its termination unit/module.</li> </ol>  |
| E08   | Analog output high.   | Bad termination device.  | Verify the termination device is set for current output.   |
|   |   | Bad cable.   | Remove the bad cable and replace it with a known good cable.   |
|   |   | Bad station.   | Remove the SAC station with the E07 error and replace it with a known good station.  |
|   |   | Bad CIS module.  | Remove the bad CIS module and replace it with a known good module.   |
| E10, E11, E12 and E13   | Module generated error codes. The station only displays the occurrence of the error. There is no station related corrective action. |  |  |
| E16   | Membrane pushbutton fault.  | User pressing multiple pushbuttons.  | Keypad is OK. Cycle through the alarm list to clear out the E16 error.   |
|   |   | E16 generated without user intervention.                                   | This is an indication of a keypad failure. Remove the station with the E16 error and replace it with a known good station.   |
| E17   | Station fault.  | COP watchdog time-out or hard failure of microprocessor.                   | <p>Reset the station.</p> <ol style="list-style-type: none"> <li>1. If the station is in bypass operation, secure control of the process loop by some other source.</li> <li>2. Open the legend door and turn the captive screw to release the station.</li> <li>3. Grasp the station faceplate at the left edge. Pull the station from the station housing.</li> <li>4. Insert the station in the station housing. Push on the left side of the faceplate until the station seats in the termination cable connector at the rear of the housing.</li> <li>5. Turn the captive screw to lock the station in place.</li> <li>6. Allow the station to initialize or enter stand-alone mode.</li> <li>7. Check for error code E17.</li> <li>8. If the station continues to display E17, replace the failed station with a working station.</li> </ol> |

Table 5-1. Corrective Action for SAC Error Codes (continued)

| Condition | Problem                         | Cause  | Corrective Action   |
|-----------|---------------------------------|--|---|
| E18       | Configuration register failure. | Station firmware unable to configure micro-processor for normal operation. | <p>Reset the station.</p> <ol style="list-style-type: none"> <li>1. If the station is in bypass operation, secure control of the process loop through some other source.</li> <li>2. Open the legend door and turn the captive screw to release the station.</li> <li>3. Grasp the station faceplate at the left edge. Pull the station from the station housing.</li> <li>4. Insert the station in the station housing. Push on the left edge of the faceplate until the station seats in the termination cable connector at the rear of the housing.</li> <li>5. Turn the captive screw to lock the station in place.</li> <li>6. Allow the station to initialize or enter stand-alone mode.</li> <li>7. Check for error code E18.</li> <li>8. If the station continues to display E18, replace the failed station with a working station.</li> </ol> |
| E19       | Display option error.           | Wrong display options selected with electric drive option enabled.         | <p>Refer to <a href="#">Section 3</a> for display option information.</p> <ol style="list-style-type: none"> <li>1. Check the stand-alone display options and verify that they are set correctly for operation with electric drives.</li> <li>2. Check the bypass display options and verify that they are set correctly for operation with electric drives.</li> </ol>   |
| E20       | M/A switch position.            | M/A switch is in the <b>M</b> position during station initialization.      | <p>Place the M/A switch in the <b>A</b> position.</p> <ol style="list-style-type: none"> <li>1. Open the legend door.</li> <li>2. Move the switch from the <b>M</b> to the <b>A</b> position.</li> <li>3. Grasp the station faceplate at the left edge. Pull the station from the station housing.</li> <li>4. Seat P5 connector on station.</li> <li>5. Insert the station in the station housing. Push on the left edge of the faceplate until the station seats in the termination cable connector at the rear of the housing.</li> </ol>  |

**NOTE:**

1. The M/A switch reset feature to correct this error only applies to SAC stations having firmware B.3 or higher.

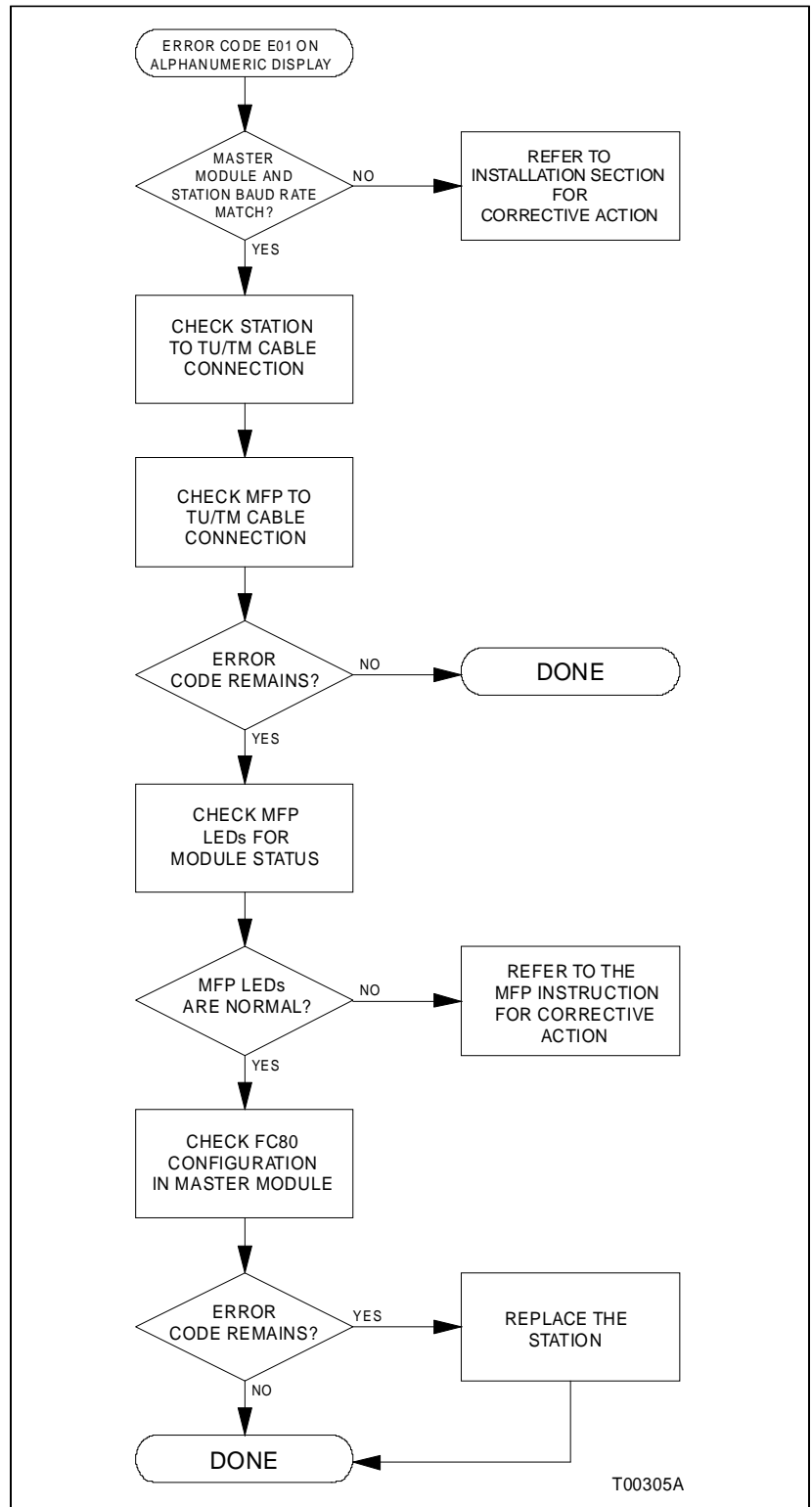

Figure 5-1. Error Code E01 Troubleshooting Flowchart

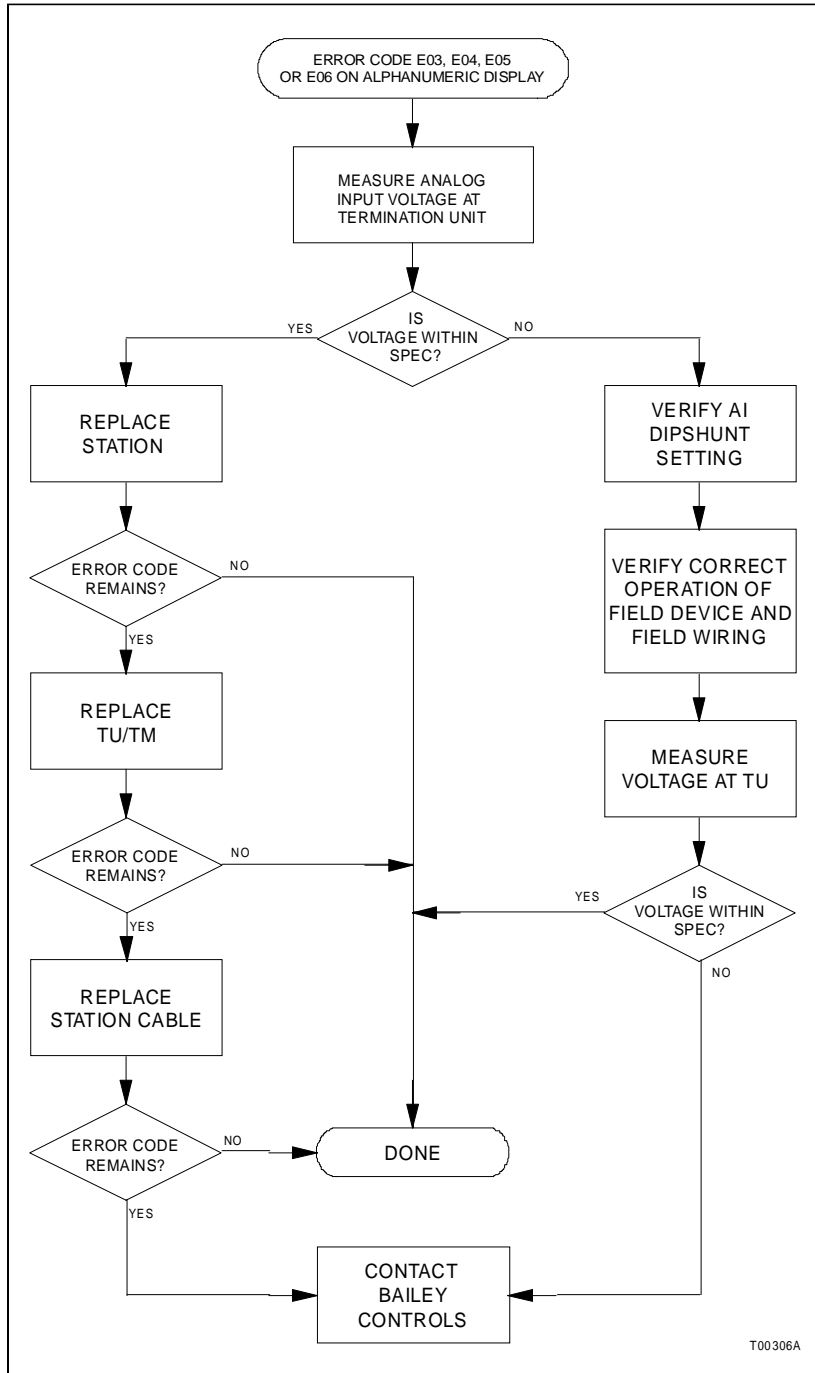

Figure 5-2. Error Codes E03, E04, E05 and E06 Troubleshooting Flowchart

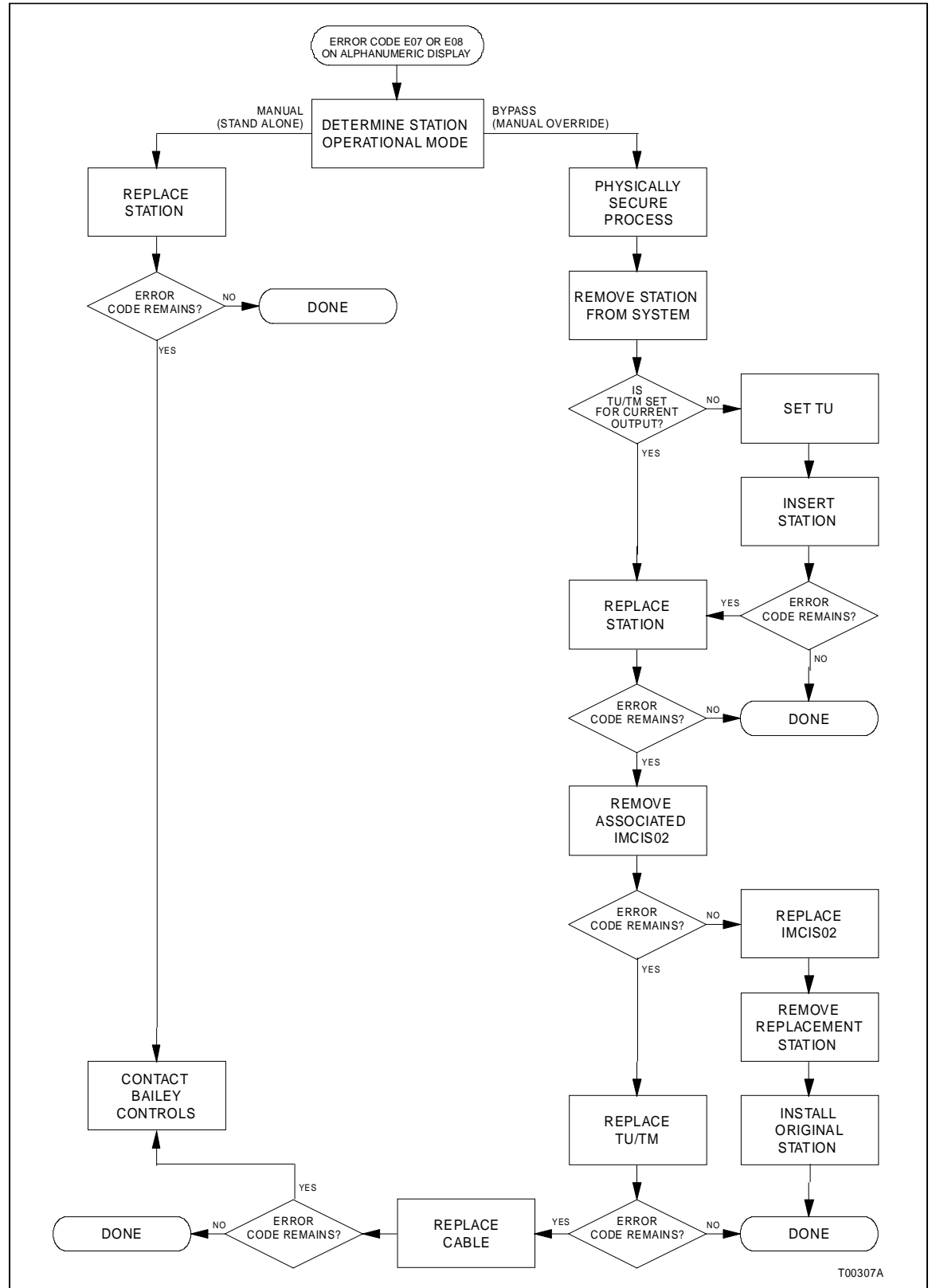

Figure 5-3. Error Codes E07 and E08 Troubleshooting Flowchart

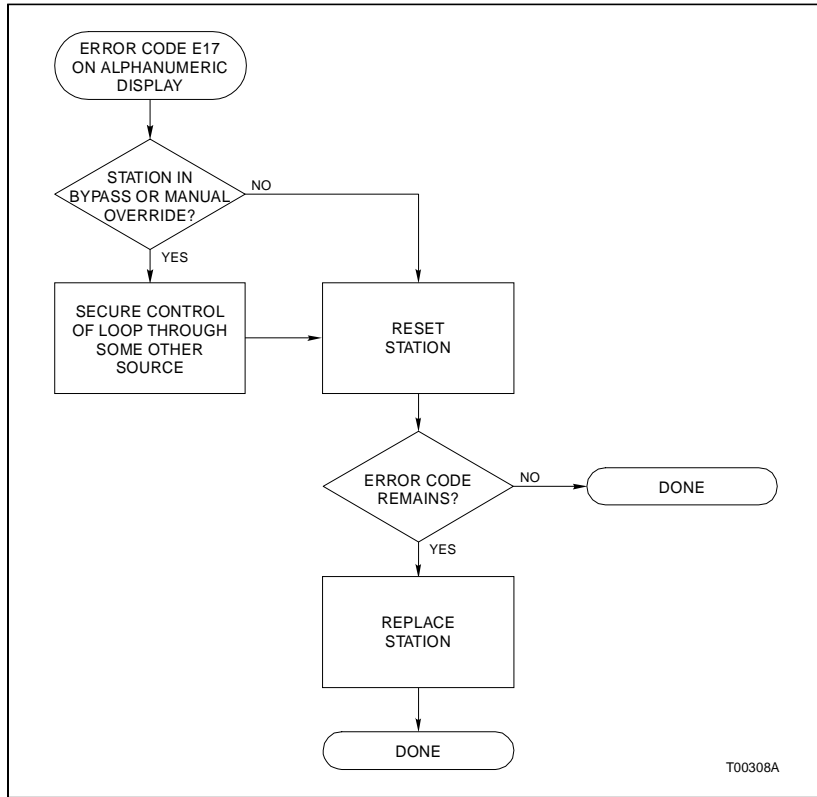

Figure 5-4. Error Code E17 Troubleshooting Flowchart

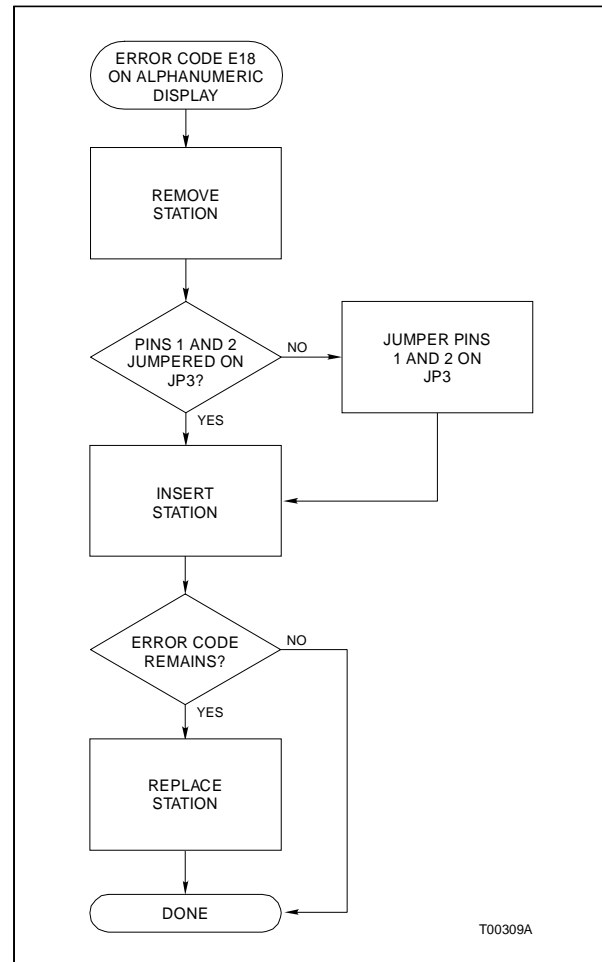
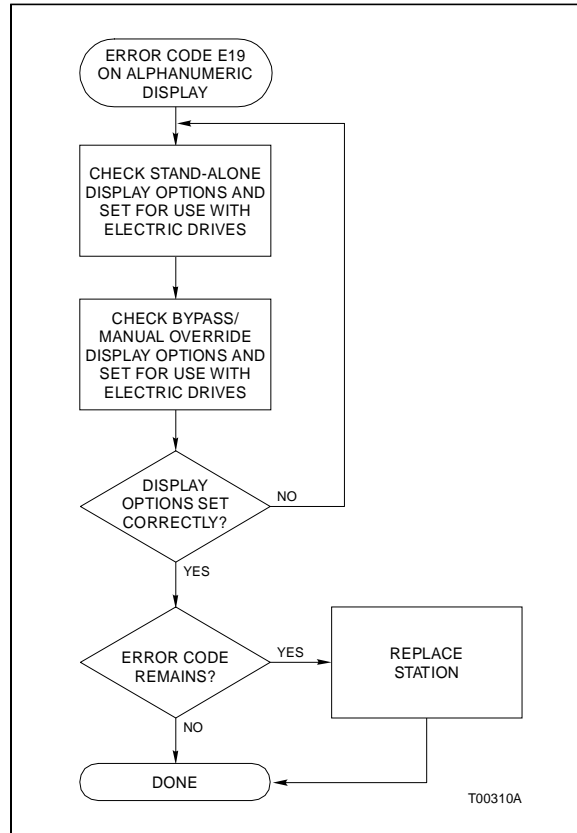

Figure 5-5. Error Code E18 Troubleshooting Flowchart



*Figure 5-6. Error Code E19 Troubleshooting Flowchart*



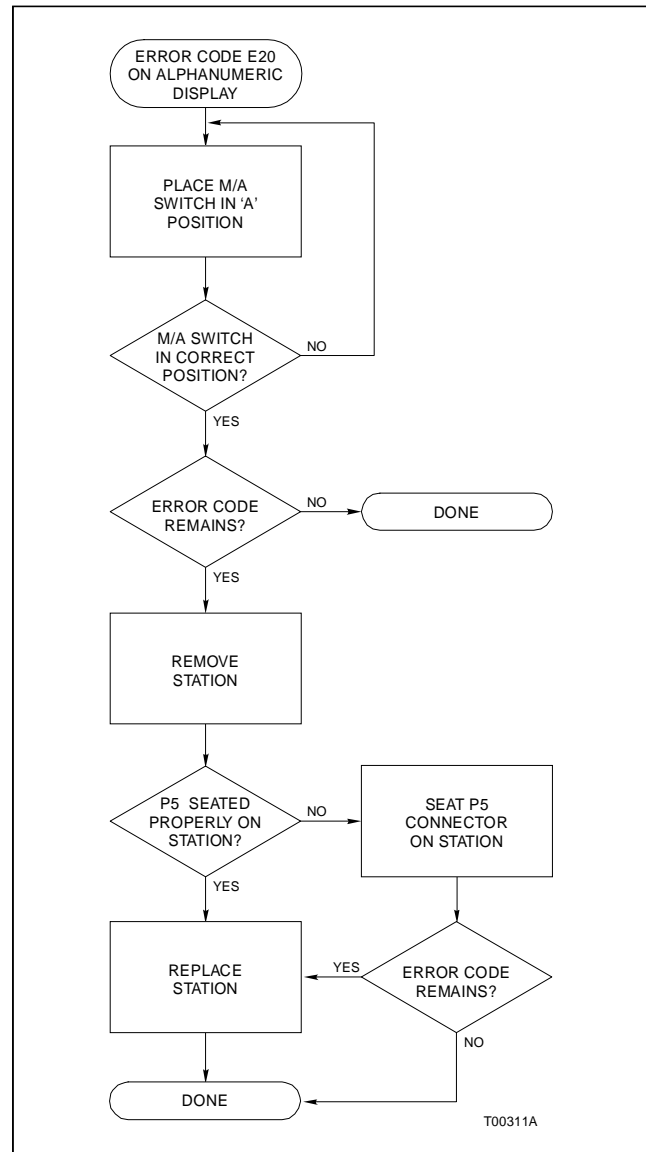
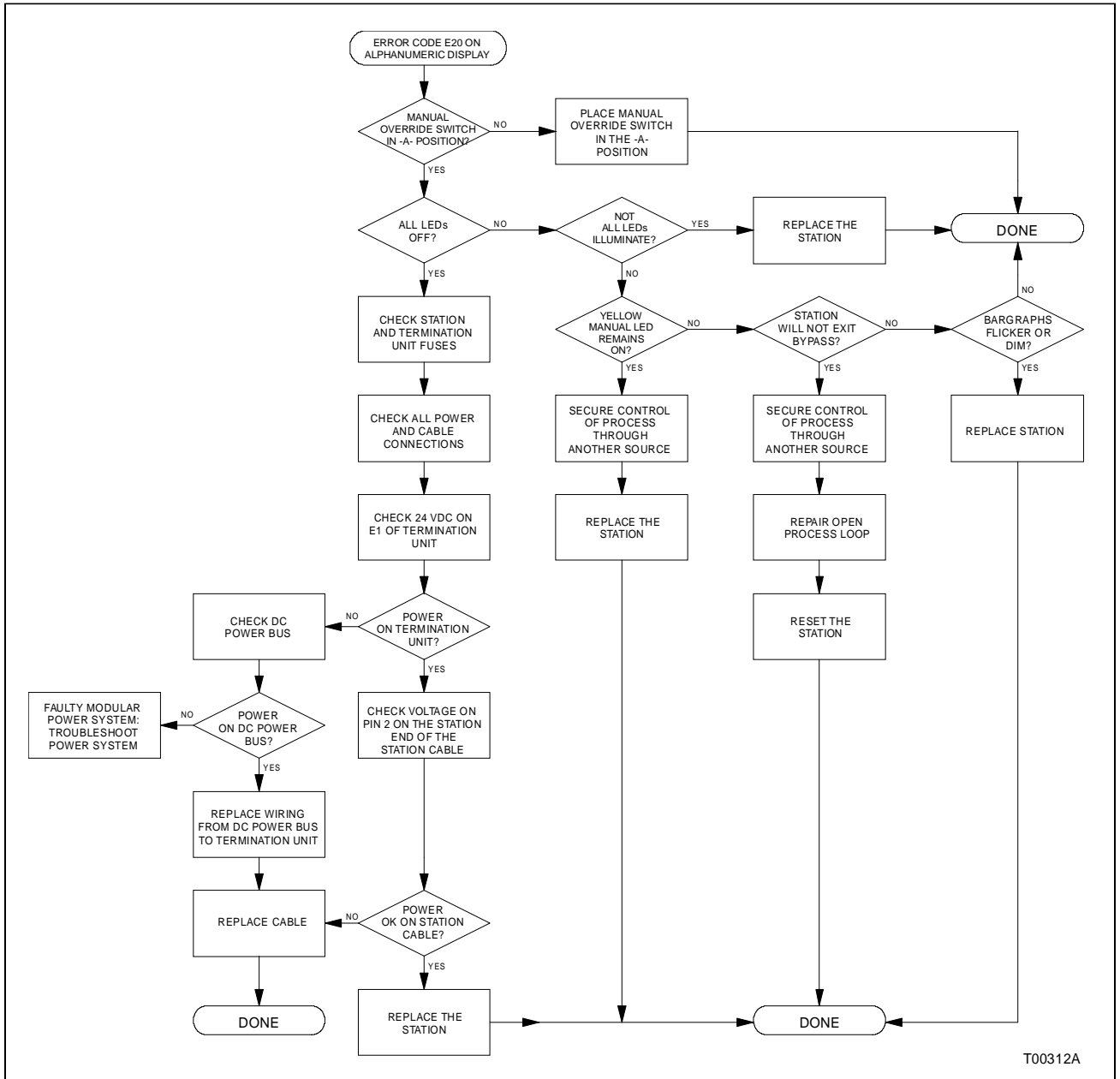

Figure 5-7. Error Code E20 Troubleshooting Flowchart

Table 5-2. Troubleshooting General Failures

| Condition                               | Cause   | Corrective Action  |
|---|---|--|
| All LEDs remain off.                    | No power.   | —  |
|   | 1. Blown fuse.  | <p>Check the station and termination unit fuses.</p> <ol style="list-style-type: none"> <li>1. Open the legend door and turn the captive screw to release the station.</li> <li>2. Grasp the left edge of the faceplate and pull the station from the station housing.</li> <li>3. Check the station fuse F1. If it is open replace it with a 1.0 A/250 V fuse (Bailey part number 1948182A21001).</li> <li>4. If the station fuse is good, check F1 and F3 on the TCS termination unit. If it is open replace with a 4.0 A/250 V fuse.</li> <li>5. Insert the station in its housing and turn the captive screw to lock it in place.</li> </ol>               |
|   | 2. Improper installation of station.                              | Check all power connections to the termination unit and termination cable connection to the station housing.   |
|   | 3. Bad cables or wiring.  | <p>Check the continuity of the 24 VDC wiring to the termination device.</p> <ol style="list-style-type: none"> <li>1. Use a digital voltmeter to verify that there is 24 VDC on the termination device. Measure the voltage across the terminal E2 and common E1.</li> <li>2. If there is no power on the termination device, check for 24 VDC on the DC power bus.</li> <li>3. If there is power on the DC power bus, remove the power wiring from the termination device and replace it with wiring that has continuity.</li> <li>4. If there is no 24 VDC on the DC power bus there is a modular power system failure.</li> </ol> <p>Replace the cable.</p> |
|   | 4. Machine fault.   | Replace the station.   |
| Yellow manual indicator remains on.     | Machine fault during bypass operation.                            | <p>Secure control of the loop by some other means.</p> <p>Replace the station.</p>   |
| Station will not exit bypass operation. | Faulty field wiring associated with the CIS module analog output. | <p>Secure control of the loop by some other means.</p> <ol style="list-style-type: none"> <li>1. Repair field wiring.</li> <li>2. Toggle the M/A switch under faceplate door from <b>A</b> to <b>M</b> and back to <b>A</b>. Only use this feature when faulty field wiring is the known source of failure.</li> </ol>   |
| LEDs not illuminated, dim or flicker    | Defective display.  | Replace the station.   |



T00312A

Figure 5-8. Troubleshooting Flowchart for General Operational Failures

---

## SECTION 6 - MAINTENANCE

---

### INTRODUCTION

The reliability of any stand-alone product or control system is affected by the maintenance of the equipment. Bailey Controls Company recommends that all equipment users practice a preventive maintenance program that will keep the equipment operating at an optimum level.

This section presents procedures that can be performed on-site. These preventive maintenance procedures should be used as guidelines to assist you in establishing good preventive maintenance practices. Select the minimum steps required to meet the cleaning needs of your system.

Personnel performing preventive maintenance should meet the following qualifications:

- Personnel should be qualified electrical technicians or engineers that know the proper use of test equipment.
- Personnel should be familiar with the IISAC01 Analog Control Station (SAC), have experience working with process control systems, and know what precautions to take when working on live AC systems.

---

### PREVENTIVE MAINTENANCE SCHEDULE

|                      |   |
|----------------------|---|
| <b>WARNING</b>       | <b>Wear eye protection whenever working with cleaning solvents. When removing solvents from printed circuit boards using compressed air, injury to the eyes could result from splashing solvent as it is blown off the printed circuit board.</b> |
| <b>AVERTISSEMENT</b> | <b>Portez toujours des lunettes de protection lorsque vous utilisez des solvants de nettoyage. L'air comprimé servant à enlever le solvant des cartes de circuits imprimés provoque des éclaboussures qui risquent d'atteindre les yeux.</b>      |

Table 6-1 is the preventive maintenance schedule for the SAC station. The table lists the preventive maintenance tasks in groups according to their specified maintenance interval. Some tasks in Table 6-1 are self explanatory. Instructions for tasks that require further explanation are covered under **PREVENTIVE MAINTENANCE PROCEDURES**.

**NOTE:** The preventive maintenance schedule is for general purposes only. Your application may require special attention.

Table 6-1. Preventive Maintenance Schedule

| Task   | Frequency |
|--|-----------|
| Check SAC faceplate, circuit board and housing for dust. Clean as necessary using an antistatic vacuum.  | 3 months  |
| Check all signal, power and ground connections associated with the SAC station and its termination device; verify that they are secure. See procedure. |           |
| Check circuit boards, giving particular attention to power contacts. Clean as necessary. See procedure.  | 12 months |
| Complete all tasks in this table.  | Shutdown  |

The following items should not be serviced on the IISAC01 Analog Control Station. Do not attempt to:

1. Calibrate the SAC station.
2. Adjust the SAC station bar graph intensity.
3. Replace discrete components on the SAC station.

---

**EQUIPMENT AND TOOLS REQUIRED**

The following are the tools and equipment required for maintenance procedures.

- Antistatic vacuum.
- Clean, lint-free cloth.
- Compressed air.
- Eberhard Faber (400A) pink pearl eraser.
- Fiberglass or nylon burnishing brush.
- Foam tipped swab.
- Bladed screwdriver.
- Isopropyl alcohol (99.5% electronic grade).
- Natural bristle brush.

---

**PREVENTIVE MAINTENANCE PROCEDURES**

This section covers tasks from Table 6-1 (preventive maintenance schedule) that require specific instruction or further explanation. The tasks and instructions covered are:

- Printed circuit board cleaning.
- How to check signal, power and ground connections.

---

### **Printed Circuit Board Cleaning**

There are several circuit board cleaning procedures in this section. These procedures cover circuit board cleaning, cleaning edge connectors and circuit board edge connector contacts. Use the procedures that meet the needs of each circuit board. Remove all dust, dirt, oil, corrosion or any other contaminant from the circuit board.

Do all cleaning and handling of the printed circuit boards at static safe work stations. Always observe the steps under **SPECIAL HANDLING** in Section 3 when handling printed circuit boards.

---

### **GENERAL CLEANING AND WASHING**

If the printed circuit board needs minor cleaning, remove dust and residue from the printed circuit board surface using clean, dry, filtered compressed air or an antistatic field service vacuum cleaner.

Another method of washing the printed circuit board is:

1. Clean the printed circuit board by spraying or wiping the board with a foam tipped swab wetted in isopropyl alcohol (99.5% electronic grade).
2. When the circuit board is clean, remove excess solvent by using compressed air to blow it free of the circuit board.

---

### **EDGE CONNECTOR CLEANING**

To clean edge connector contacts:

1. Use a solvent mixture of 80% isopropyl alcohol (99.5% electronic grade) and 20% distilled water.
2. Soak a lint-free cloth with the solvent mixture.
3. Work the cloth back and forth parallel to the edge connector contacts.
4. Repeat with a clean cloth that is soaked with the solvent mixture.
5. Dry the edge connector contact area by wiping with a clean lint-free cloth.

To clean tarnished or deeply stained edge connector contacts:

1. Use an Eberhard Faber (400A) pink pearl eraser, or equivalent to remove tarnish or stains. Fiberglass or nylon burnishing brushes may be used also.

2. Minimize electrostatic discharge by using the 80/20 isopropyl alcohol and water solution during burnishing.
3. Do not use excessive force while burnishing. Use only enough force to shine the contact surface. Inspect the edge connector after cleaning to assure no loss of contact surface.

---

### ***FEMALE EDGE CONNECTOR CLEANING***

To clean the contacts on a female edge connector:

1. Use a foam tipped swab or a lint-free cloth wrapped over a piece of scrap circuit board. Soak the swab or cloth in electronic grade isopropyl alcohol.
2. Insert the swab of cloth covered circuit board into edge connector and work it back and forth to clean the contacts.
3. Rinse the edge connector contacts by spraying with isopropyl alcohol.
4. Remove excess alcohol, and dry using compressed air.

---

### ***Checking Connections***

Check all signal wiring, power and ground connections within the cabinet to verify their integrity. When checking connections, always turn a screw, nut or other fastening device in the direction to tighten only. If the connection is loose, it will be tightened. If the connection is tight, the tightening action will verify that it is secure. There must not be any motion done to loosen the connection.

**NOTE:** Bailey Controls Company recommends this preventive maintenance task be performed during power supply preventive maintenance while the power to the cabinet is off.

1. Verify that all field wiring connections are secure.
2. Check all cable connections.

---

# SECTION 7 - REPAIR/REPLACEMENT PROCEDURES

---

## INTRODUCTION

This section explains the replacement procedures for an IISAC01 Analog Control Station. There are no special tools required to replace an analog control station (SAC). Table 7-1 lists the recommended spare parts for the SAC station.

**NOTE:** Always use the Bailey field static kit (part number 1948385A1) when working with the station. This kit connects the static dissipative work surface and technician to the same ground point.

*Table 7-1. Recommended Spare Parts List*

| Description          | Part Number   |
|----------------------|---------------|
| Fuse, 1.0 A, 250 VDC | 1948182A21001 |

If you determine the SAC station is faulty, replace it with a new one. **Do not** try to repair the station; replacing components may affect the control loop performance. To replace a station:

1. If the station is in bypass or manual override mode, secure control of the process prior to removing the station from a system under power. The station in stand-alone or normal mode can be removed from a system under power.
2. Use a straight blade screwdriver to turn the captive screw located behind the legend door and release the station from its housing.
3. Grasp the station faceplate at the left edge and pull the station from its housing.
4. Set the replacement station display and operating options (dipswitch and jumper settings). Insure that the replacement station options are set the same as the options on the original station. If you modify any of the options, record and date the change in the space provided in each table of [Section 3](#).
5. Insert the replacement station in the station housing. Push on the left edge of the faceplate until P1 on the SAC station circuit board seats in the cable connector at the rear of the housing.
6. Tighten the captive screw located behind the legend door and lock the station in place.
7. Return to normal operation.



---

**STATION FUSE (F1) REPLACEMENT**

To replace the station fuse:

1. Use a straight blade screwdriver to turn the captive screw located behind the legend access door and release the station from the station housing.
2. Grasp the station faceplate at the left edge and pull the station from its housing.
3. Remove F1 from the fuse holder (see Figure 3-1 for the location of F1).
4. Replace F1 by installing a 1.0 A/250 V fuse (Bailey part number 1948182A21001) in the fuse holder.
5. Insert the station in the station housing. Push on the left edge of the faceplate until P1 on the SAC station circuit board seats in the cable connector at the rear of the housing.
6. Lock the station in place by turning the captive screw.

---

## SECTION 8 - SUPPORT SERVICES

---

### **INTRODUCTION**

Bailey Controls Company is ready to assist in the use of its products. Requests for sales, applications services, installation, repair, overhaul and maintenance contract services should be made to the nearest sales office.

---

### **REPLACEMENT PARTS AND ORDERING INFORMATION**

If you are making repairs at your own facility, replacement parts should be ordered through a Bailey sales office. Provide the following information for parts orders:

1. Part description, part number and quantity.
2. Model, serial number (if applicable) and ratings of the assembly containing the ordered part.
3. Bailey publication number and reference used in identifying the part. When ordering standard parts from Bailey Controls Company, use the part number and description from the replacement parts section of the manual. Parts not having a commercial description in the replacement parts section must be ordered from a Bailey Controls Company sales office.

---

### **TRAINING**

Bailey Controls Company has a modern training facility available for training your personnel. On-site training is also available. Contact a Bailey Controls Company sales office for specific information and scheduling.

---

### **TECHNICAL DOCUMENTATION**

Obtain additional copies of this instruction through the nearest Bailey Controls Company sales office. Copies, over and above those provided with the original purchase, are available at a minimum charge to the customer. Contact a Bailey Controls Company sales office for information.

# APPENDIX A - NTCS04 CONTROLLER/STATION TERMINATION UNIT

## INTRODUCTION

The IISAC01 Analog Control Station uses the NTCS04 Controller/Station Termination Unit for termination. Configure the termination unit dipshunts according to the assembly revision level you are using. All NTCS04 termination units have two analog inputs available to each station connector.

One dipshunt (XU8) on the NTCS04 termination unit selects the analog inputs for both station connectors. Table A-1 shows the dipshunt configuration and analog inputs for both station connectors (two stations per termination unit can have bypass). All other dipshunt settings on the NTCS04 termination unit relate to the IMCIS02 Control I/O Slave Module. Refer to the **IMCIS02 Control I/O Slave Module** product instruction for information about setting the dipshunts for the module. Figure A-1 shows the NTCS04 termination unit terminal assignments.

**NOTE:** Use the NKCS02 or NKCS12 termination unit to station cable (for interconnection) to access both analog inputs.

Table A-1. NTCS04 Termination Unit Dipshunt Configuration

| Analog input (with Station Feedback)                              |  |
|---|--|
| Application/Signal Type   | Dipshunt Configuration XU8 (Station Designator/Analog Input)   |
| Station 1 (P2 connector) station/termination unit A/I designation | <div style="display: flex; justify-content: space-around; font-size: small;"> <span>(A12/A11)</span> <span>(A11/A13)</span> </div> |
| Station 2 (P3 connector)  | <div style="display: flex; justify-content: space-around; font-size: small;"> <span>(A12/A12)</span> <span>(A11/A14)</span> </div> |

TP25080B

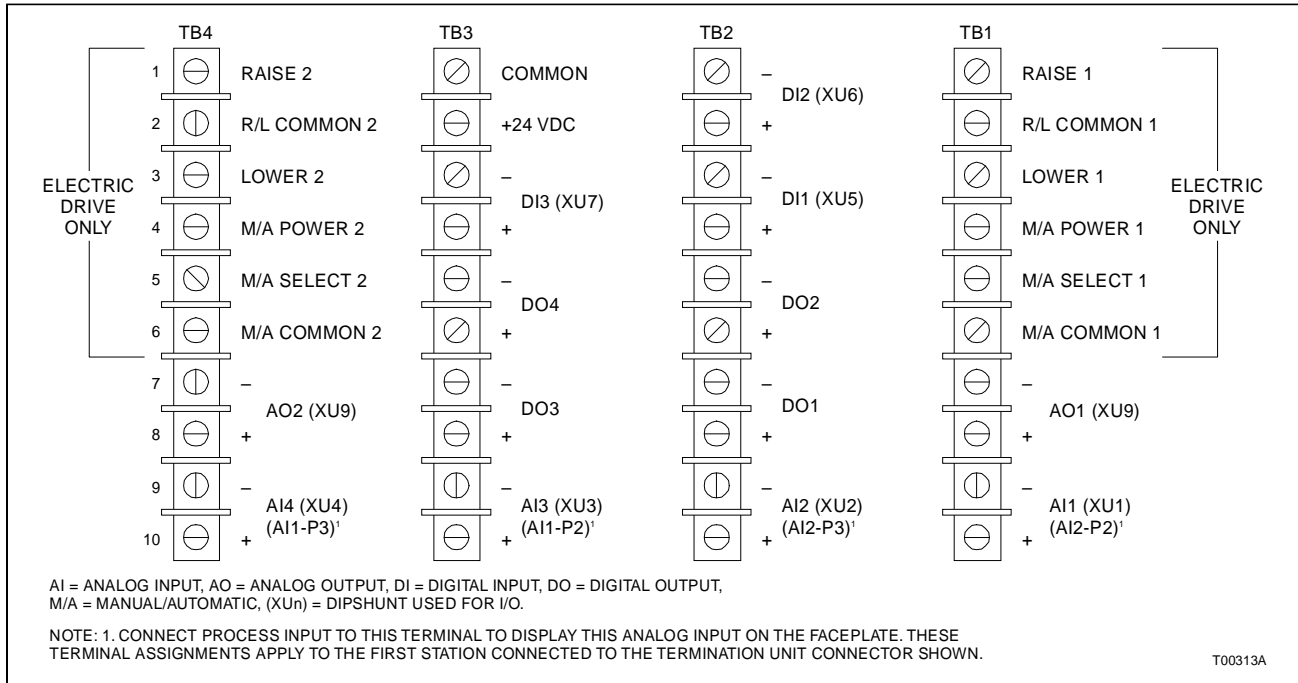

Figure A-1. NTCS04 Terminal Assignments

# APPENDIX B - NICS01 CONTROLLER/STATION TERMINATION MODULE

## INTRODUCTION

The IISAC01 Analog Control Station can use the NICS01 Controller/Station Termination Module for termination. All dipswitch settings on the controller/station termination module (ICS) relate to the IMCIS02 Control I/O Slave Module. Refer to the **IMCIS02 Control I/O Slave Module** product instruction for more information.

No analog inputs are routed to the station when using the ICS termination module. For bypass and analog input capability, the NIDS01 Station Termination Module and the ICS termination module are required.

**NOTE:** Terminating one or two stations with bypass, or interconnecting stations using the ICS module requires that you install the NIDS01 termination module. There are no dipswitch settings on the NIDS01 termination module.

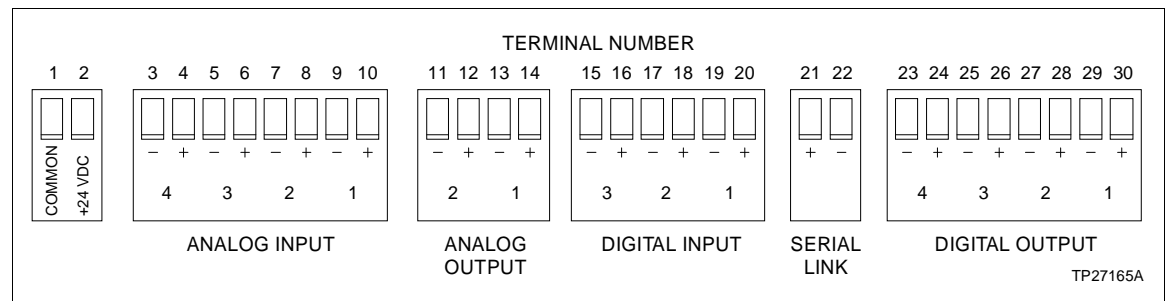

Figure B-1. NICS01 Terminal Assignments

# APPENDIX C - NIDS01 STATION TERMINATION MODULE

## INTRODUCTION

The IISAC01 Analog Control Station (SAC) can use the NIDS01 Station Termination Module (IDS) for termination.

The IDS termination module used in conjunction with the NICS01 Controller/Station Termination Module provides bypass capability and an electric drive termination for SAC stations. For more information on the IDS termination module refer to the **NIDS01 Station Termination Module** product instruction.

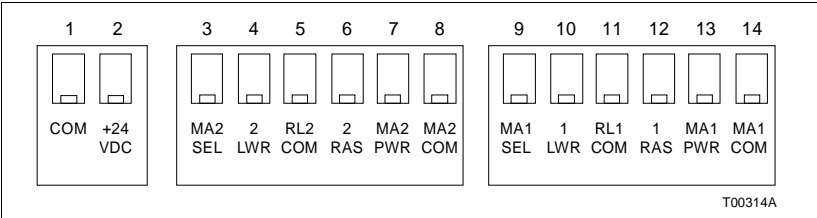

Figure C-1. NIDS01 Terminal Assignments

|  |                  |
|--|------------------|
| <b>A</b>                                     |                  |
| Alarms .....                                 | 4-2              |
| Analog control station functions .....       | 2-4              |
| Annunciators .....                           | 4-4              |
| Application .....                            | 2-2              |
| <b>C</b>                                     |                  |
| Cable  |                  |
| Applications .....                           | 3-13             |
| Connections .....                            | 3-13             |
| ICS and IDS termination modules .....        | 3-21             |
| NIRL03 termination module .....              | 3-16, 3-19       |
| NTCS04 termination unit .....                | 3-16, 3-17       |
| NTRL03 termination unit .....                | 3-16, 3-18       |
| Length .....                                 | 3-11, 3-13, 3-14 |
| Checking connections .....                   | 6-4              |
| Configuration                                |                  |
| Basic station .....                          | 2-10             |
| Cascade set point from external source ..... | 2-11             |
| Ratio station .....                          | 2-12             |
| <b>D</b>                                     |                  |
| Dipshunt configuration .....                 | A-1              |
| SW1 .....                                    | 3-3, 3-4         |
| SW2 .....                                    | 3-5              |
| SW3 .....                                    | 3-7, 3-10        |
| SW4 .....                                    | 3-8, 3-9, 3-10   |
| Display options .....                        | 3-6              |
| Bypass/manual override mode .....            | 3-8              |
| Electric drive mode .....                    | 3-10             |
| Manual override .....                        | 3-9              |
| Normal mode .....                            | 3-8              |
| Square root enable .....                     | 3-7              |
| Stand-alone mode .....                       | 3-7              |
| <b>E</b>                                     |                  |
| Error codes .....                            | 4-2, 5-1         |
| Corrective action .....                      | 5-2              |
| E01 .....                                    | 5-2, 5-5         |
| E02 .....                                    | 5-2              |
| E03 .....                                    | 5-2, 5-6         |
| E04 .....                                    | 5-2, 5-6         |
| E05 .....                                    | 5-2, 5-6         |
| E06 .....                                    | 5-2, 5-6         |
| E07 .....                                    | 5-2, 5-3, 5-7    |
| E08 .....                                    | 5-3, 5-7         |
| E10 .....                                    | 5-3              |
| E11 .....                                    | 5-3              |
| E12 .....                                    | 5-3              |
| E13 .....                                    | 5-3              |
| E17 .....                                    | 5-3, 5-8         |
| E18 .....                                    | 5-4, 5-9         |
| E19 .....                                    | 5-4, 5-10        |
| E20 .....                                    | 5-4, 5-11        |
| Example configuration .....                  | 1-3              |
| <b>F</b>                                     |                  |
| Faceplate operation .....                    | 4-1              |
| Alphanumeric display .....                   | 4-1              |
| Annunciators .....                           | 4-4              |
| Bar graph displays .....                     | 4-4              |
| Manual override switch .....                 | 4-4              |
| Membrane pushbuttons .....                   | 4-4              |
| Special characters .....                     | 4-2              |
| Features .....                               | 1-2              |
| Flow diagram .....                           | 2-5              |
| Function code configuration .....            | 3-23             |
| Fuse replacement .....                       | 7-2              |
| <b>G</b>                                     |                  |
| Glossary .....                               | 1-4              |
| <b>H</b>                                     |                  |
| Hardware                                     |                  |
| Application .....                            | 1-2              |
| Description .....                            | 1-1              |
| How to use this instruction .....            | 1-4              |
| <b>I</b>                                     |                  |
| Inserting the station .....                  | 3-22             |
| Installation .....                           | 3-1              |
| Station housing .....                        | 3-22             |
| Termination module .....                     | 3-17, 3-19       |
| Termination unit .....                       | 3-15             |
| Instruction content .....                    | 1-3              |
| Intended user .....                          | 1-1              |
| Introduction .....                           | 1-1              |
| <b>J</b>                                     |                  |
| Jumper settings .....                        | 3-6              |
| <b>L</b>                                     |                  |
| Locations                                    |                  |
| Dipswitch .....                              | 3-2              |
| Jumper .....                                 | 3-2              |

# Index (continued)

## M

|                                       |      |
|---------------------------------------|------|
| Maintenance .....                     | 6-1  |
| Maximum number of stations .....      | 1-2  |
| Microcomputer mode of operation ..... | 3-11 |
| Modes of operation .....              | 2-5  |
| Basic station .....                   | 2-9  |
| Bypass operation .....                | 2-6  |
| Cascade station .....                 | 2-10 |
| Computer and local .....              | 2-8  |
| Computer .....                        | 2-9  |
| Local .....                           | 2-9  |
| Initialization .....                  | 2-6  |
| Manual override .....                 | 2-7  |
| Normal .....                          | 2-8  |
| Ratio station .....                   | 2-12 |
| Stand-alone operation .....           | 2-6  |
| Mounting .....                        |      |
| Dimensions .....                      | 3-12 |
| Station housing .....                 | 3-11 |

## N

|                                 |     |
|---------------------------------|-----|
| NICS01 termination module ..... | B-1 |
| NIDS01 termination module ..... | C-1 |
| Nomenclature .....              | 1-7 |
| NTCS04 termination unit .....   | A-1 |

## O

|                            |     |
|----------------------------|-----|
| Operating procedures ..... | 4-1 |
| Ordering information ..... | 8-1 |

## P

|   |      |
|---|------|
| Panel cutout .....                      | 3-12 |
| Preventive maintenance procedures ..... | 6-2  |
| Checking connections .....              | 6-4  |
| Printed circuit board cleaning .....    | 6-3  |
| Printed circuit board cleaning .....    | 6-3  |

## R

|                                     |      |
|-------------------------------------|------|
| Reference documents .....           | 1-6  |
| Removing the station .....          | 3-23 |
| Repair/replacement procedures ..... | 7-1  |
| Replacement parts .....             | 8-1  |
| Required tools and equipment .....  | 6-2  |

## S

|                                   |      |
|-----------------------------------|------|
| SAC station I/O circuitry .....   | 2-13 |
| Analog input .....                | 2-18 |
| Analog output .....               | 2-18 |
| Bypass circuitry .....            | 2-14 |
| Electric drive .....              | 2-16 |
| Scheduled maintenance .....       | 6-1  |
| Selecting options .....           | 3-2  |
| Auto bypass .....                 | 3-4  |
| Communication rate .....          | 3-3  |
| Demand output .....               | 3-5  |
| Diagnostics .....                 | 3-3  |
| Electric drive option .....       | 3-5  |
| Station address .....             | 3-4  |
| Spare parts list .....            | 7-1  |
| Special handling .....            | 3-1  |
| Specifications .....              | 1-8  |
| Start-up and operation .....      | 4-6  |
| Acknowledging alarms .....        | 4-9  |
| Bypass/manual override .....      | 4-9  |
| Changing control strategies ..... | 4-8  |
| Normal operation .....            | 4-8  |
| Stand-alone .....                 | 4-7  |
| Station bypass circuitry .....    | 2-15 |
| Support services .....            | 8-1  |
| System operation .....            | 2-1  |

## T

|  |            |
|--|------------|
| Technical documentation .....                | 8-1        |
| Terminal assignments .....                   |            |
| NICS01 termination module .....              | B-1        |
| NIDS01 termination module .....              | C-1        |
| NTCS04 termination unit .....                | A-2        |
| Training .....                               | 8-1        |
| Troubleshooting .....                        | 5-1        |
| All LEDs off .....                           | 5-12       |
| General failures .....                       | 5-12, 5-13 |
| LEDs not illuminated, dim or flicker .....   | 5-12       |
| Station will not exit bypass operation ..... | 5-12       |
| Yellow manual indicator on .....             | 5-12       |

## U

|                                |     |
|--------------------------------|-----|
| Unpacking and inspection ..... | 3-2 |
|--------------------------------|-----|



Visit *Elsag Bailey* on the World Wide Web at <http://www.bailey.com>

---

Our worldwide staff of professionals is ready to meet *your* needs for process automation.  
For the location nearest you, please contact the appropriate regional office.

**AMERICAS**

29801 Euclid Avenue  
Wickliffe, Ohio USA 44092  
Telephone 1-216-585-8500  
Telefax 1-216-585-8756

**ASIA/PACIFIC**

152 Beach Road  
Gateway East #20-04  
Singapore 189721  
Telephone 65-391-0800  
Telefax 65-292-9011

**EUROPE, AFRICA, MIDDLE EAST**

Via Puccini 2  
16154 Genoa, Italy  
Telephone 39-10-6582-943  
Telefax 39-10-6582-941

**GERMANY**

Graefstrasse 97

D-60487 Frankfurt Main  
Germany  
Telephone 49-69-799-0  
Telefax 49-69-799-2406